

AGLP-2 Parallel Gripper

T-Slot Bearing Series, Low Profile

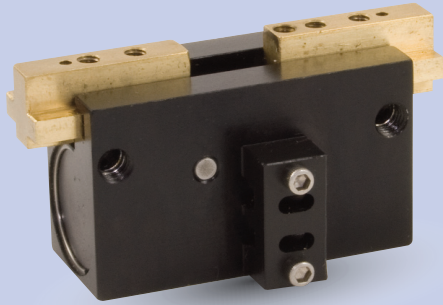

FEATURES AND BENEFITS

- Jaws are T-Slot bearing supported to prevent jaw breakage and offer superior load bearing performance.
- Rugged rack and pinion synchronizing.
- High gripping force to weight ratio.
- Compact design with long stroke.
- True parallel jaw motion for easy tooling.
- Units are permanently lubricated for non-lube air operation, allowing for compliance with OSHA regulations.
- Hall effect sensors are available to monitor open and closed position of the jaws.
- AGLP is fully field repairable for cost savings and minimum down time

SPECIFICATIONS

Design: Parallel, Double Acting, Synchronized Jaws

Stroke: 0.50 in [12.7 mm]

Gripping Force @ 80 PSI [5.5 BAR]

Closing: 10 lbs [44 N]
 Opening: 10 lbs [44 N]

Time:

Close: 0.12 sec [0.12 sec]
 Open: 0.12 sec [0.12 sec]

Pressure Range:

Low/High 10-100 PSI [.7-7 BAR]

Temperature Range:

Low/High -20°/180°F [-28°/80°C]

Side Play:

± 0.001 [.03 mm]

Loading Capacity:

	Static	Dynamic
Max Tensile T	65 lbs [289 N]	20 lbs [89 N]
Max Compressive C	65 lbs [289 N]	20 lbs [89 N]

Max Moment M_x 60 in/lb [6.7 Nm] 15 in/lb [1.6 Nm]

Max Moment M_y 60 in/lb [6.7 Nm] 20 in/lb [2.2 Nm]

Max Moment M_z 60 in/lb [6.7 Nm] 15 in/lb [1.6 Nm]

Max Moment M_z 60 in/lb [6.7 Nm] 15 in/lb [1.6 Nm]

Material: High Strength, Hard Coated aluminum bronze alloys, Steel

Weight: 2 oz [56 g]

Piston Diameter: .625 in [15.8 mm]

January 2008 - PATENTED Made in the USA

HOLDING FORCES CHART

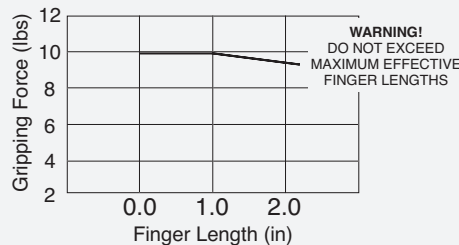

WARNING! Do not exceed tooling jaw length. See Chart above.

LOADING INFORMATION

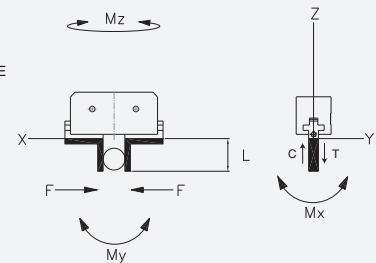

LOOK! More Technical specifications for sensors on "Sensors Accessories" page.

HOW TO ORDER

When ordering, please specify:
 Design/Model Number and Options.

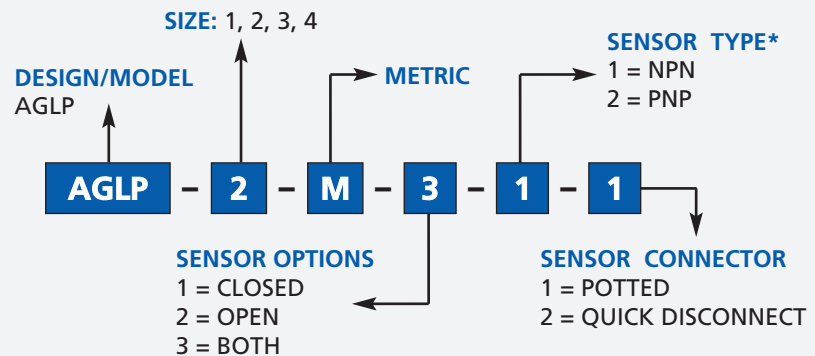

* NOTE: Hall Effect 4mm dia., 5-24 VDC, 22 mA and comes with 2 meter cable or quick disc.

Sensor Part # SHN01, SHN03, SHP01, SHP03

AGLP-2 Parallel Gripper

T-Slot Bearing Series, Low Profile

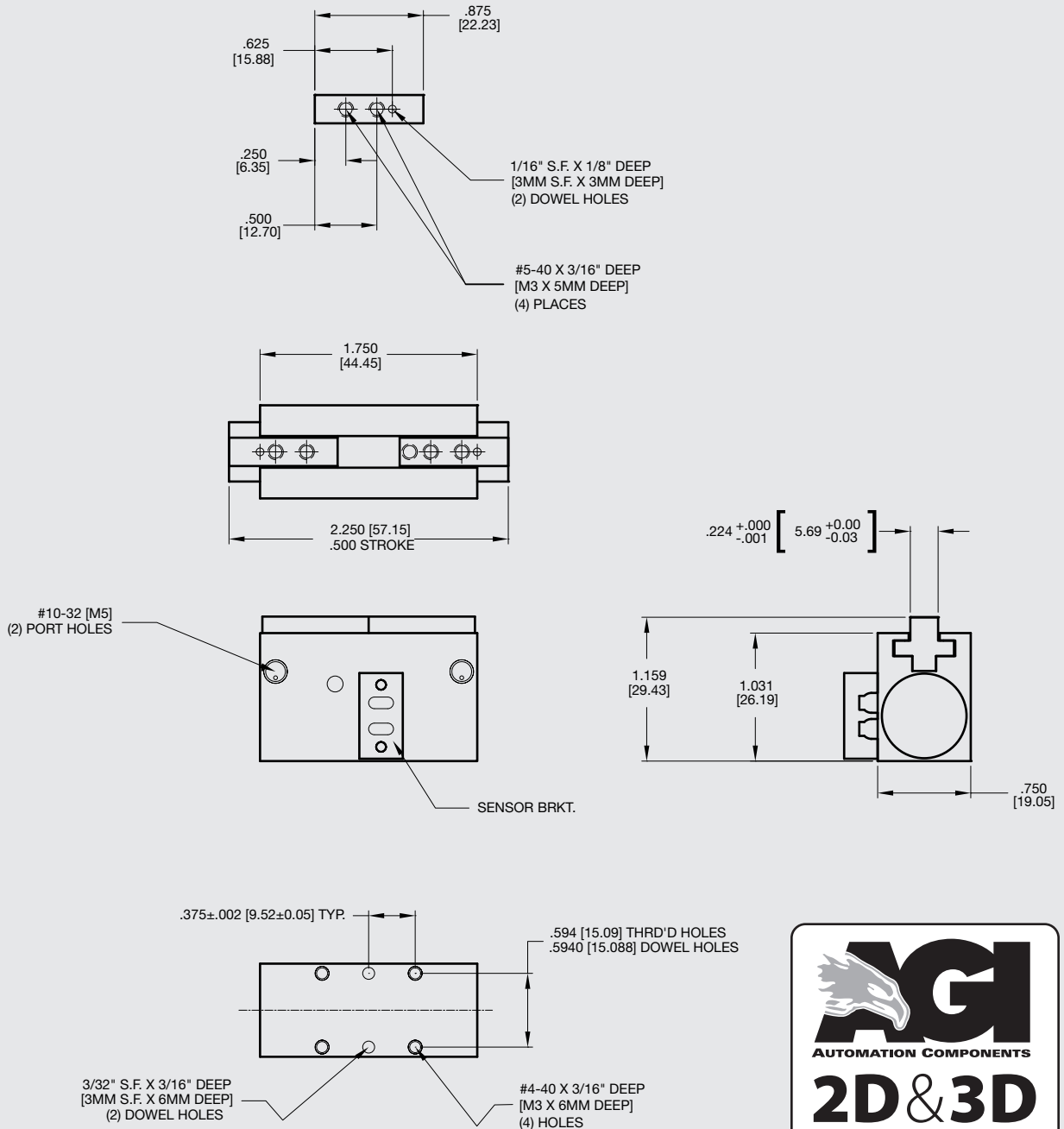

Unless noted, all tolerances are as indicated here:



All Dowel Holes are SF (Slip Fit) Locational Tolerance $\pm .0005"$ [0.13mm]



Metric Threads Course Pitch

Imperial:
Inch 0.00 = ± 0.1
0.000 = ± 0.005
0.0000 = ± 0.0005

Metric: [0.] = ± 0.25
[mm] [0.0] = ± 0.13
[0.00] = ± 0.13