

AGP-250 Parallel Gripper

Double Guided Wedge



FEATURES AND BENEFITS

- Jaws machined from S7 tool steel to prevent jaw breakage.
- Ultra high gripping force to weight ratio.
- True parallel jaw motion for easy tooling.
- Units are permanently lubricated for non-lube air operation, this allowing for compliance with OSHA regulations.
- Additional side mounting holes and side air ports for optional mounting and porting available.
- Proximity switches are available to monitor open and closed position of the jaws.
- Fully field repairable for cost savings and minimum down time.

SPECIFICATIONS

Design: Parallel, Double Acting, Synchronized Jaws

Stroke: 0.25 in [6.3 mm]

Gripping Force @ 80 PSI [5.5 bar]:

Closing: 20 lbs [89 N]

Opening: 22 lbs [97 N]

Time:

Close: 0.2 sec [0.2 sec]

Open: 0.2 sec [0.2 sec]

Pressure Range: 30-120 PSI [2-8 bar]

Temperature Range: -20°-180°F [-28°-80°C]

Side Play: ± 0.001 [0.03 mm]

Repeatability from center:
±.002 [0.06 mm]

Loading Capacity:

	Static	Dynamic
Max Tensile T	100 lbs [444 N]	15 lbs [66.7 N]
Max Compressive C	150 lbs [667 N]	25 lbs [111 N]

	90 in/lb [10 Nm]	15 in/lb [1.7 Nm]
Max Moment Mx	90 in/lb [10 Nm]	15 in/lb [1.7 Nm]
Max Moment My	90 in/lb [10 Nm]	15 in/lb [1.7 Nm]
Max Moment Mz	90 in/lb [10 Nm]	15 in/lb [1.7 Nm]

Material: High Strength, Hard Coated aluminum bronze alloys, Steel

Weight: 4 oz. [113 g]

Piston Diameter: 1.00 in [25.4 mm]

January 2008 - PATENTED Made in the USA

HOLDING FORCES CHART

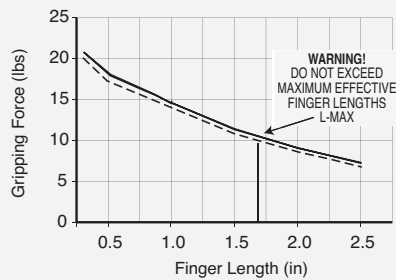

WARNING! Do not exceed tooling jaw length. See Chart above.

LOADING INFORMATION

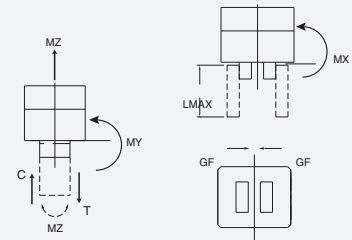

LOOK! More Technical specifications for sensors on "Sensors Accessories" page.

HOW TO ORDER

When ordering, please specify:
Design/Model Number and Options.

DESIGN/MODEL
AGP-250

METRIC

SENSOR TYPE*

1 = NPN

2 = PNP

AGP-250 - M - 3 - 1 - 1

SENSOR OPTIONS

- 1 = CLOSED
- 2 = OPEN
- 3 = BOTH

SENSOR CONNECTOR

- 1 = POTTED
- 2 = QUICK DISCONNECT
- 3 = QUICK DISCONNECT WITH RIGHT ANGLE

* NOTE: Proximity sensors are 4 mm dia., 12-30 VDC, 50 mA and comes with 2 meter cable or quick disc.

Sensor Part # SNC04, SNQ04, SPC04, SPQ04

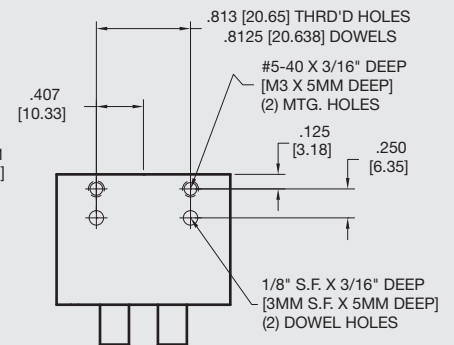
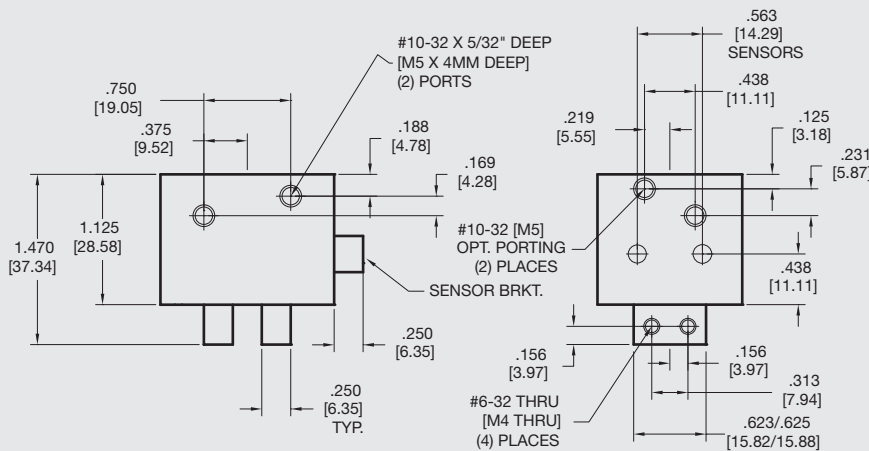
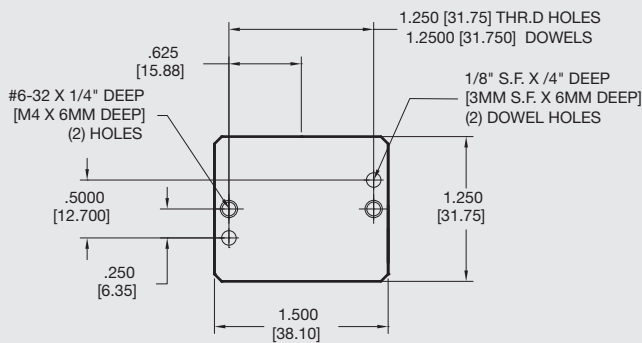

Unless noted, all tolerances are as indicated here:



All Dowel Holes are SF (Slip Fit) Locational Tolerance $\pm .0005"$ [0.13mm]



Metric Threads Course Pitch

Imperial:
Inch 0.00 = $\pm .01$
0.000 = $\pm .005$
0.0000 = $\pm .0005$

Metric: [0.] = $\pm .25$
[mm] [0.0] = $\pm .13$
[0.00] = $\pm .013$