

AGP-6-OR Parallel Gripper

6-Finger Gripper for Placing O-Rings, T-Slot Bearing Series



FEATURES AND BENEFITS

- Jaws are T-Slot bearing supported to prevent jaw breakage and offer superior load bearing performance.
- Spreading jaws and Ejector jaws have independent pistons to provide exact timing of O-ring placement.
- Compact design with long adjustable stroke.
- True parallel jaw motion for easy tooling.
- Available in Metric only.

SPECIFICATIONS

Design: Parallel, Double Acting, Synchronized Sealed Jaws

Stroke: Spread 0.6 in. adj. [15 mm]
Ejecting 0.25 in [6.3 mm]

Gripping Force Per Jaw @ 80 PSI [5.5 BAR]
Spreading Jaw: 62 lbs [275 N]
Ejector Jaw: 80 lbs [355 N]

Time:
Close: 0.2 sec [0.2 sec]
Open: 0.2 sec [0.2 sec]

Pressure Range:
Low/High 30-100 PSI [2-7 BAR]

Temperature Range:
Low/High -20°/180°F [-28°/80°C]

Side Play: ± 0.001 [.03 mm]

Repeatability from center: ±.002 [.06 mm]

Loading Capacity:

	Static	Dynamic
Max Tensile T	60 lbs [260 N]	20 lbs [88 N]
Max Compressive C	60 lbs [260 N]	20 lbs [88 N]
Max Moment M_x	100 in/lb [11 Nm]	25 in/lb [2.7 Nm]
Max Moment M_y	120 in/lb [13 Nm]	30 in/lb [3.3 Nm]
Max Moment M_z	100 in/lb [11 Nm]	25 in/lb [2.7 Nm]

Material: High Strength, Hard Coated aluminum bronze alloys, Steel

Weight: 1.25 lbs [.56 Kg]

Piston Diameter: 1.00 in [25.4 mm]

January 2008 - PATENTED Made in the USA

HOLDING FORCES CHART

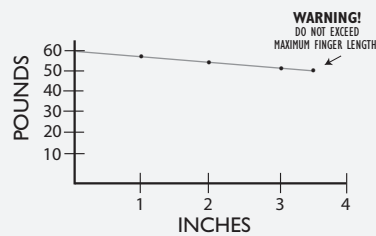

WARNING! Do not exceed tooling jaw length. See Chart above.

LOADING INFORMATION

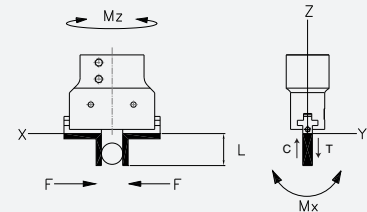

LOOK! More Technical specifications for sensors on "Sensors Accessories" page.

HOW TO ORDER

When ordering, please specify:
Design/Model Number and Options.

DESIGN/MODEL

AGP-6-OR

AGP-6-OR - 3 - 1 - 1

SENSOR OPTIONS

- 1 = JAW OPEN
- 2 = EJECTOR DOWN
- 3 = BOTH

SENSOR TYPE*

- 1 = NPN
- 2 = PNP

SENSOR CONNECTOR

- 1 = POTTED
- 2 = QUICK DISCONNECT
- 3 = QUICK DISCONNECT WITH RIGHT ANGLE

* NOTE: Proximity sensors are 4 mm dia., 12-30 VDC, 50 mA and comes with 2 meter cable.

Sensor Part # SNC06, SNQ06, SPC06, SPQ06

AGP-6-OR Parallel Gripper

6-Finger Gripper for Placing O-Rings, T-Slot Bearing Series

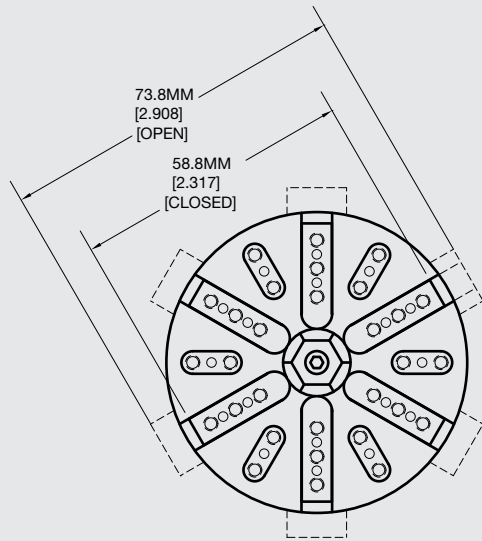

METRIC PROJECTION

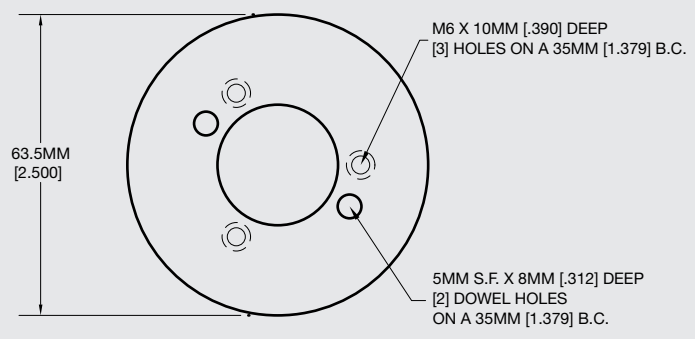
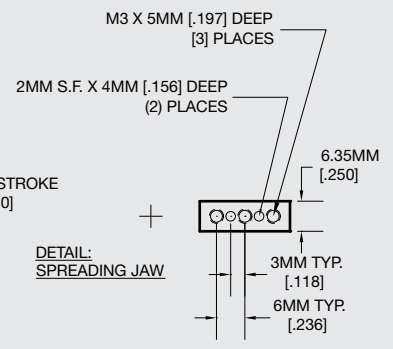
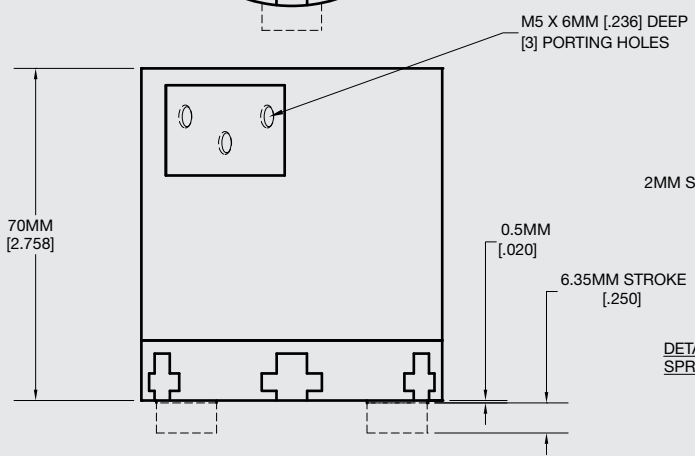
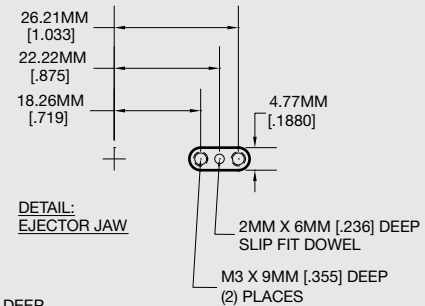

AGI
AUTOMATION COMPONENTS
2D & 3D
Download 2D & 3D CAD Files
@ www.AGI-Automation.com

Unless noted, all tolerances are as indicated here:

	All Dowel Holes are SF (Slip Fit) Locational Tolerance ± .0005" [.013mm]		Metric Threads Course Pitch	Imperial: 0.00 = ±.01 0.000 = ±.005 0.0000 = ±.0005	Metric: [0.] = ±.25 [0.0] = ±.13 [0.00] = ±.013
---	--	---	-----------------------------	---	---