

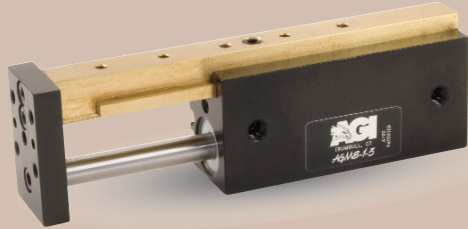

AGMS-1-3 Mini Powered Slide

Built-In Air Cylinder



FEATURES AND BENEFITS

- T-Slot bearing support for the carriage and end plate offers superior load bearing performance throughout the stroke.
- Standard built-in stroke adjustment and stroke lock for precise, repetitive operation.
- Compact, lightweight unit with built-in cylinder.
- Piston seals are U-CUP type for long service life.
- Hall Effect sensors are available to monitor stroke position.
- Multiple mounting surfaces on the body and endplate with threaded and counterbored holes for easy mounting choices.

SPECIFICATIONS

Design: Built-in air cylinder
T-slot slide

Stroke: 1.5 in [38.1 mm]

Thrust Force @ 80 PSI [5.5 BAR]

Extended: 15 lbs [66.7 N]
Retract: 13 lbs [57.8 N]

Recommended Speed:

2-12 in/sec
[0.5-.3m/sec]

Pressure Range:

Low/High 20-120 PSI [1.4-8 BAR]

Temperature Range:

Low/High -20°/150°F [-28°/80°C]

Side Play:

± 0.001 [0.03 mm]

Maximum Payload:

12 lbs [5.4 kg]

Material: High Strength, Aluminum Alloys, Bronze

Weight:

4 oz [113 g]

Piston Diameter:

.50 in [12.7 mm]

January 2008 - PATENTED Made in the USA

MAXIMUM FORCES & MOMENTS

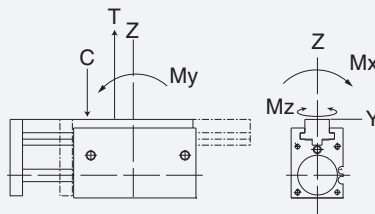

	Static	Dynamic
Max Tensile T	100 lbs [444 N]	42 lbs [186 N]
Max Compressive C	100 lbs [444 N]	42 lbs [186 N]
Max Moment M_x	80 in/lb [9 Nm]	40 in/lb [4.5 Nm]
Max Moment M_y	80 in/lb [9 Nm]	40 in/lb [4.5 Nm]
Max Moment M_z	80 in/lb [9 Nm]	40 in/lb [4.5 Nm]

HOW TO ORDER

When ordering, please specify:
Design/Model Number and Options.

DESIGN/MODEL

- AGMS-1-1
- AGMS-1-2
- AGMS-1-3
- AGMS-1-4

METRIC

AGMS-1-3 M - 3 - 1 - 1

SENSOR TYPE

- 1 = NPN
- 2 = PNP

SENSOR OPTIONS*

- 1 = LEFT
- 2 = RIGHT
- 3 = BOTH

SENSOR CONNECTOR

- 1 = POTTED
- 2 = QUICK DISCONNECT
- 3 = QUICK DISCONNECT WITH RIGHT ANGLE

* NOTE: Hall Effect sensors – Potted or Quick disconnect.

Sensor Part # SHN01, SHP01, SHNQ3, SHPQ3

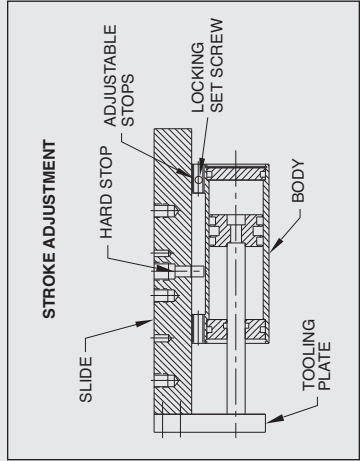
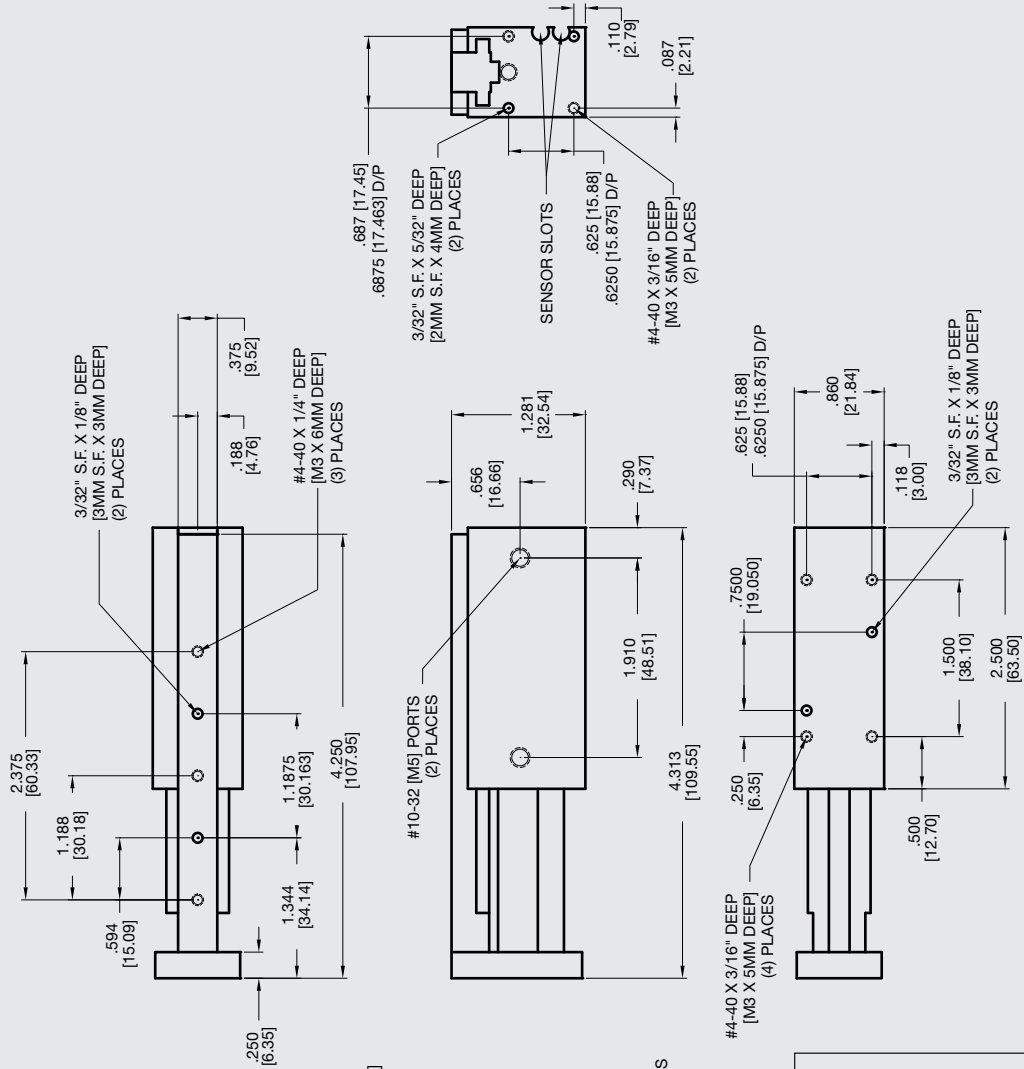

Unless noted, all tolerances are as indicated here:

 All Dowel Holes are SF (Slip Fit) Locational Tolerance ± .0005" [0.13mm]

 Metric Threads Course Pitch

Imperial: 0.00 = ±.01
Inch 0.000 = ±.005
0.0000 = ±.0005

Metric: [0.] = ±.25
[mm] [0.0] = ±.13
[0.00] = ±.013