

**IAI**

Quality and Innovation

SPLASH-PROOF SINGLE-AXIS ROBOT

# ISWA/ISPWA



[www.intelligentactuator.com](http://www.intelligentactuator.com)

**First in the industry!**  
**The lineup of splash-proof sliders has been extended.**  
**You can now choose a splash-proof actuator of desired size to match your specific application.**



**Features**

- The new slider structure keeps water out of the internal parts. When air purge is performed, the robot conforms to IP65. (Note 1)  
 The high-speed robot achieves a maximum speed of 1,000 mm/sec. (Note 2)
- The maximum load capacity is 70 kg, so heavy loads can be transferred effortlessly. (Note 3)
- The high-precision specification (ISPWA) with a C5-equivalent precision rolled screw boasts a positioning repeatability of ±0.01 mm.  
 The standard specification (ISWA) also ensures high accuracy equivalent to ±0.02 mm.
- Select from the three sizes of S (94 mm wide), M (125 mm wide) and L (155 mm wide).

(Note 1) The protection class is IP54 without air purge.  
 (Note 2) M type, 200 W/20-mm lead.  
 (Note 3) M type, 100 W/5-mm lead or 200 W/10-mm lead.  
 L type, 200W/10-mm lead or 400W/20-mm lead.

**Example of Use**

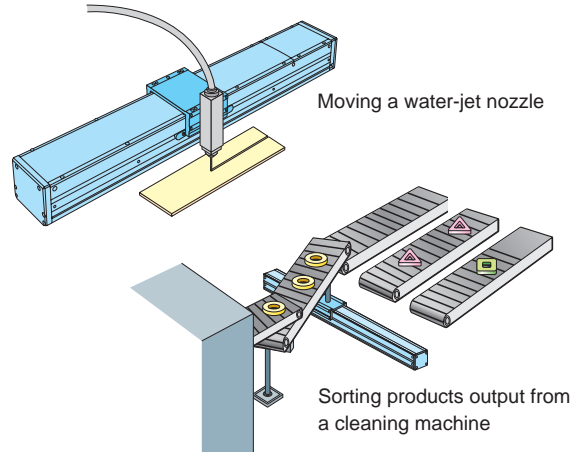

**Model**

**Actuator Model**

<b>ISWA</b>	<b>-</b>	<b>M</b>	<b>-</b>	<b>A</b>	<b>-</b>	<b>200</b>	<b>-</b>	<b>20</b>	<b>-</b>	<b>500</b>	<b>-</b>	<b>T1</b>	<b>-</b>	<b>M</b>	<b>-</b>	<b>RT</b>
Series		Type		Encoder type		Motor Output		Lead		Stroke		Applicable controller		Cable length		Options
ISWA Standard specification ISPWA: High-precision specification		S: Actuator width 94 mm M: Actuator width 125 mm L: Actuator width 155 mm		A: Absolute I: Incremental		60:60W 100:100W 200:200W 400:400W		4:4mm 5:5mm 8:8mm 10:10mm 16:16mm 20:20mm		100~1200mm * Varies depending on the model.		T1: XSEL-J/K E-Con P-Driver T2: XSEL-P/Q		N: No cable S:3m M:5m X□□: Specify the desired length. * The standard cable is a robot cable.		RT: Guide with ball-retaining mechanism

**Controller Model** See the back cover.

\* The selectable leads vary depending on the model.

**Specification Table**

	Stroke (mm) and maximum speed (mm/sec) (Note 1)															Load capacity (Note 2)		Motor (W)	Lead (mm)	Model															
																Horizontal (kg)	Vertical (kg)																		
	100	150	200	250	300	350	400	450	500	550	600	650	700	750	800	850	900				950	1000	1050	1100	1150	1200									
Slider type Motor straight type	800										760					7	-	60	16	IS(P)WA-S-60-16-□□□															
	400										380					20	-		8	IS(P)WA-S-60-8-□□□															
	200										190					45	-		4	IS(P)WA-S-60-4-□□□															
	500					455					365					300					250					30	-	100	10	IS(P)WA-M-100-10-□□□□					
	250					225					180					150					125					70	-		5	IS(P)WA-M-100-5-□□□□					
	1000					915					735					600					500					30	-	200	20	IS(P)WA-M-200-20-□□□□					
	500					455					365					300					250					70	-		10	IS(P)WA-M-200-10-□□□□					
	1000					930					765					640					545					465					30	-	200	20	IS(P)WA-L-200-20-□□□□
	500					465					380					320					270					230					70	-		10	IS(P)WA-L-200-10-□□□□
1000					930					765					640					545					465					70	-	400	20	IS(P)WA-L-400-20-□□□□	

(Note 1) The figure in each band indicates the maximum speed at the applicable stroke.  
 (Note 2) The load capacity is based on operation at an acceleration of 0.3 G.

**Notes on Use**

- ◎ The ISWA/ISPWA must always be used in a horizontal application in the specified orientation. Be sure to observe this requirement, since water will enter the housing if these robots are positioned on their side or used in a vertical application.
- ◎ The protection class of each splash-proof model indicates protection against entry of water. Please contact IAI if you require protection against oil and coolant.
- ◎ Be sure to implement air purge if the robot is used in a humid place (humidity of 85% or above). The purge air must be clean, dry air supplied from an air drier.





# ISWA-M-200 Single-Axis Robot, Medium Splash-Proof Type, Actuator Width 125 mm, 200 W, Straight Shape

# ISPWA-M-200 Single-Axis Robot, Medium Splash-Proof Type, Actuator Width 125 mm, 200 W, Straight Shape High-precision specification

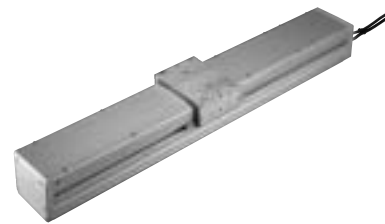

Type	Medium splash-proof	Stroke	100-1000mm	Load capacity	70 kg (horizontal)
<b>Model specification items</b> Series Type Encoder type Motor output Lead Stroke Controller Cable length Options (Example) ISWA [ISPWA]- M - A - 200 - 20 - 1000 - T1 - S - RT					

## Model/Specifications

Model	Encoder Type	Motor output (W)	Lead (mm)	Stroke (in increments of 50-mm)	Speed (Note 1) (mm/s)	Load capacity (kg) (Note2)		Rated thrust (N)
						Horizontal (kg)	Vertical (kg)	
ISWA [ISPWA]-M- [1]-200-20- [2]- [3]- [4]- [5]	A: Absolute	200	20	100-1000	1000	30	—	169.5
ISWA [ISPWA]-M- [1]-200-10- [2]- [3]- [4]- [5]	I: Incremental		10			70	—	340.1

\*[1],[2],[3],[4]and[5]in the model numbers shown above respectively indicate the encoder type, stroke, applicable controller, cable length and applicable options.

## Options

Names	Type	Pages	Remarks
Guide with ball-retaining mechanism	RT	—	

## Common Specifications

Drive System (Note 3)	Ball screw, rolled C10 [rolled C5 or equivalent]
Positioning repeatability (Note 3)	±0.02mm [±0.01mm]
Backlash (Note 3)	0.05 mm or less [0.02 mm or less]
Guide	Integrated with the base
Allowable load moment	Ma: 34.8 N · m, Mb: 49.5 N · m, Mc: 80.8 N · m
Overhang load length	600 mm or less in Ma, Mb or Mc direction
Grease	Food grease (Medallion FM Grease No. 1)
Cable length (Note 4)	N: No cable, S: 3 m, M: 5 m, X□□: Specified length
Protection class (Note 5)	IP65
Operating temperature/humidity	0 ~ 40°C, 85%RH or below (non-condensing)

## Materials of Key Components

Name	Materials
Base, slider	Aluminum (A6063S-T5 or equivalent) with white alumite treatment
Side cover, screw cover	Aluminum (A6063S-T5 or equivalent) with white alumite treatment
Front cover, rear cover	A5052 with white alumite treatment
Actuator cable	PVC
Capcon	Nylon 66

## Dimensions

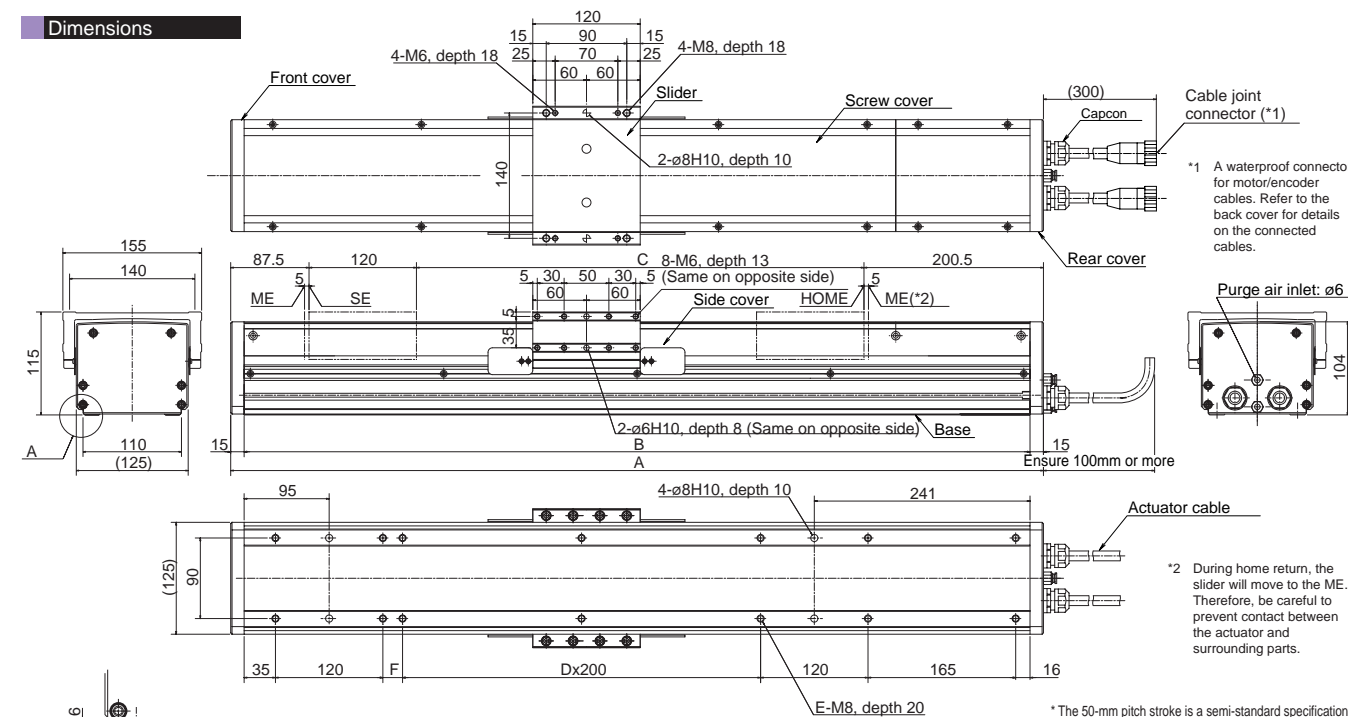

\*1 A waterproof connector for motor/encoder cables. Refer to the back cover for details on the connected cables.

\*2 During home return, the slider will move to the ME. Therefore, be careful to prevent contact between the actuator and surrounding parts.

\* The 50-mm pitch stroke is a semi-standard specification.

Stroke	(50)	100	(150)	200	(250)	300	(350)	400	(450)	500	(550)	600	(650)	700	(750)	800	(850)	900	(950)	1000
A	458	508	558	608	658	708	758	808	858	908	958	1008	1058	1108	1158	1208	1258	1308	1358	1408
B	428	478	528	578	628	678	728	778	828	878	928	978	1028	1078	1128	1178	1228	1278	1328	1378
C	50	100	150	200	250	300	350	400	450	500	550	600	650	700	750	800	850	900	950	1000
D	—	—	—	—	—	1	1	1	1	2	2	2	2	3	3	3	3	4	4	4
E	10	10	10	10	10	12	12	12	12	14	14	14	14	16	16	16	16	18	18	18
F	-28	22	72	122	172	22	72	122	172	22	72	122	172	22	72	122	172	22	72	122
Weight (kg)	11.1	11.9	12.8	13.6	14.5	15.3	16.2	17.0	17.9	18.7	19.6	20.4	21.3	22.1	23.0	23.8	24.7	25.5	26.4	27.2
Maximum speed (mm/s)	Lead 20		1000		915		735		600		500		455		365		300		250	
	Lead 10		500																	

Maximum speed (mm/s)  
\*Varies depending on the stroke.

## Applicable Controller Specifications

Applicable controller	Maximum number of controlled axes	Compatible encoder type	Operating method	Power-supply voltage
X-SEL	4 axes	Absolute/incremental	Programming	AC100V AC200V
E-Con	1 axis	Absolute/incremental	Positioner	
P-Driver	1 axis	Incremental	Pulse-train control	

**Caution**

(Note 1) A longer stroke will result in a lower maximum speed to prevent the ball screw from reaching a dangerous speed. (Refer to the above table for the maximum speed at a given stroke.)  
 (Note 2) Based on an acceleration of 0.3 G.  
 (Note 3) The figures in square brackets apply to the ISPWA series.  
 (Note 4) The maximum cable length is 30 m. Specify the desired length in meters (e.g., X08 = 8 m).  
 (Note 5) IP65 applies when air purge is performed. Without air purge, the protection class is IP54.  
 The ISWA/ISPWA must be installed horizontally. If the actuator is installed on its side or oriented vertically, water may enter the interior.

# ISWA-L-200

Single-Axis Robot, Large Splash-Proof Type,  
Actuator Width 155 mm, 200 W, Straight Shape

# ISPWA-L-200

Single-Axis Robot, Large Splash-Proof Type,  
Actuator Width 155 mm, 200 W, Straight Shape High-precision specification

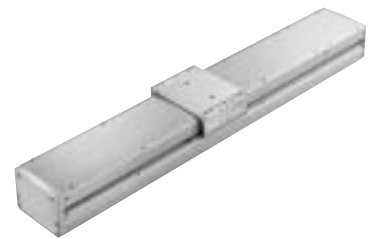

Type	Large splash-proof	Stroke	100~1200mm	Load capacity	70 kg (horizontal)
------	--------------------	--------	------------	---------------	--------------------

Model specification items	Series	Type	Encoder type	Motor output	Lead	Stroke	Controller	Cable length	Options
(Example)	ISWA-	L	- A	- 200	- 10	- 1200	- T1	- S	- RT

### Model/Specifications

Model	Encoder Type	Motor output (W)	Lead (mm)	Stroke (in increments of 50-mm)	Speed (Note 1) (mm/s)	Load capacity (kg) (Note 2)		Rated thrust (N)
						Horizontal (kg)	Vertical (kg)	
ISWA [ISPWA]-L- <sup>1</sup> - 200-20- <sup>2</sup> - <sup>3</sup> - <sup>4</sup> - <sup>5</sup>	A: Absolute	200	20	100~1200	1000	30	—	169.5
ISWA [ISPWA]-L- <sup>1</sup> - 200-10- <sup>2</sup> - <sup>3</sup> - <sup>4</sup> - <sup>5</sup>	I: Incremental		10		500	70	—	340.1

<sup>1</sup><sup>2</sup><sup>3</sup><sup>4</sup>and<sup>5</sup> in the model numbers shown above respectively indicate the encoder type, stroke, applicable controller, cable length and applicable options.

### Options

Name	Type	Page	Remarks
Guide with ball-retaining mechanism	RT	—	

### Common Specifications

Drive System (Note 3)	Ball screw, rolled C10 [rolled C5 or equivalent]
Positioning repeatability (Note 3)	±0.02mm [±0.01mm]
Backlash (Note 3)	0.05 mm or less [0.02 mm or less]
Guide	Integrated with the base
Allowable load moment	Ma: 52.5 N·m, Mb: 75.0 N·m, Mc: 124.5 N·m
Overhang load length	750 mm or less in Ma, Mb or Mc direction
Grease	Food grease (Medallion FM Grease No. 1)
Cable length (Note 4)	N: No cable, S: 3 m, M: 5 m, X□□: Specified length
Protection class (Note 5)	IP65
Operating temperature/humidity	0 ~ 40°C, 85%RH or below (non-condensing)

### Materials of Key Components

Name	Materials
Base, slider	Aluminum (A6063S-T5 or equivalent) with white alumite treatment
Side cover, screw cover	Aluminum (A6063S-T5 or equivalent) with white alumite treatment
Front cover, rear cover	A5052 with white alumite treatment
Actuator cable	PVC
Capcon	Nylon 66

### Dimensions

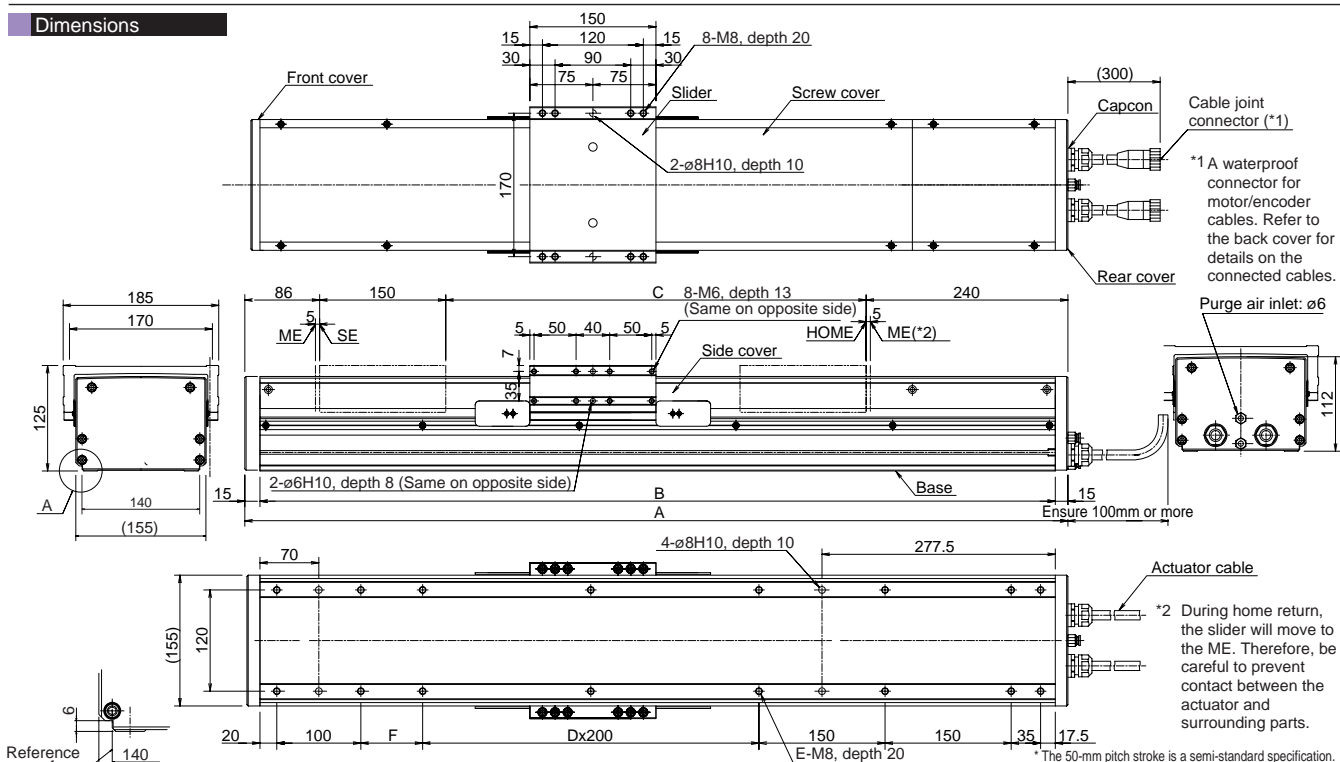

Stroke	100 (150)	200 (250)	300 (350)	400 (450)	500 (550)	600 (650)	700 (750)	800 (850)	900 (950)	1000 (1050)	1100 (1150)	1200	
A	576	626	676	726	776	826	876	926	976	1026	1076	1126	
B	546	596	646	696	746	796	846	896	946	996	1046	1096	
C	100	150	200	250	300	350	400	450	500	550	600	650	
D	—	—	—	1	1	1	1	2	2	2	3	3	
E	12	12	12	14	14	14	14	16	16	16	18	18	
F	73.5	123.5	173.5	223.5	273.5	323.5	373.5	423.5	473.5	523.5	573.5	623.5	
Weight (kg)	19.9	20.9	21.8	22.8	23.7	24.7	25.6	26.6	27.5	28.5	29.4	30.4	
Maximum speed (mm/s) <small>*Varies depending on the stroke.</small>	Lead 20	1000						930		765	640	545	465
	Lead 10	500						465		380	320	270	230

### Applicable Controller Specifications

Applicable controller	Maximum number of controlled axes	Compatible encoder type	Operating method	Power-supply voltage
X-SEL	6 axes	Absolute/incremental	Programming	AC100V AC200V
E-Con	1 axis	Absolute/incremental	Positioner	
P-Driver	1 axis	Incremental	Pulse-train control	

**Caution**

(Note 1) A longer stroke will result in a lower maximum speed to prevent the ball screw from reaching a dangerous speed. (Refer to the above table for the maximum speed at a given stroke.)  
 (Note 2) Based on an acceleration of 0.3 G.  
 (Note 3) The figures in square brackets apply to the ISPWA series.  
 (Note 4) The maximum cable length is 30 m. Specify the desired length in meters (e.g., X08 = 8 m).  
 (Note 5) IP65 applies when air purge is performed. Without air purge, the protection class is IP54.  
 The ISWA/ISPWA must be installed horizontally. If the actuator is installed on its side or oriented vertically, water may enter the interior.

# ISWA-L-400

Single-Axis Robot, Large Splash-Proof Type,  
Actuator Width 155 mm, 400 W, Straight Shape

# ISPWA-L-400

Single-Axis Robot, Large Splash-Proof Type,  
Actuator Width 155 mm, 400 W, Straight Shape **High-precision specification**

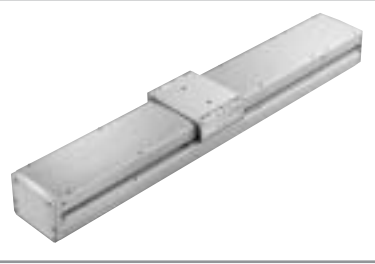

Type **Large splash-proof** Stroke **100~1200mm** Load capacity **70 kg (horizontal)**

Model specification items Series Type Encoder type Motor output Lead Stroke Controller Cable length Options  
(Example) ISWA-L-A-400-20-1200-T1-S-RT

## Model/ Specifications

Model	Encoder type	Motor output (W)	Lead (mm)	Stroke (in increments of 50-mm)	Speed (Note 1) (mm/s)	Load capacity (kg) (Note 2)		Rated thrust (N)
						Horizontal (kg)	Vertical (kg)	
ISWA [ISPWA]-L- [1] -200-20- [2] - [3] - [4] - [5]	A: Absolute I: Incremental	400	20	100~1200	1000	70	—	340.1

\*[1], [2], [3], [4] and [5] in the model numbers shown above respectively indicate the encoder type, stroke, applicable controller, cable length and applicable options.

## Options

Name	Type	Page	Remarks
Guide with ball-retaining mechanism	RT	—	

## Common Specifications

Drive System (Note 3)	Ball screw, rolled C10 [rolled C5 or equivalent]
Positioning repeatability (Note 3)	±0.02mm [±0.01mm]
Backlash (Note 3)	0.05 mm or less [0.02 mm or less]
Guide	Integrated with the base
Allowable load moment	Ma: 52.5 N·m, Mb: 75.0 N·m, Mc: 124.5 N·m
Overhang load length	750 mm or less in Ma, Mb or Mc direction
Grease	Food grease (Medallion FM Grease No. 1)
Cable length (Note 4)	N: No cable, S: 3 m, M: 5 m, X□□: Specified length
Protection class (Note 5)	IP65
Operating temperature/humidity	0 ~ 40°C, 85%RH or below (non-condensing)

## Materials of Key Components

Name	Materials
Base, slider	Aluminum (A6063S-T5 or equivalent) with white alumite treatment
Side cover, screw cover	Aluminum (A6063S-T5 or equivalent) with white alumite treatment
Front cover, rear cover	A5052 with white alumite treatment
Actuator cable	PVC
Capcon	Nylon 66

## Dimensions

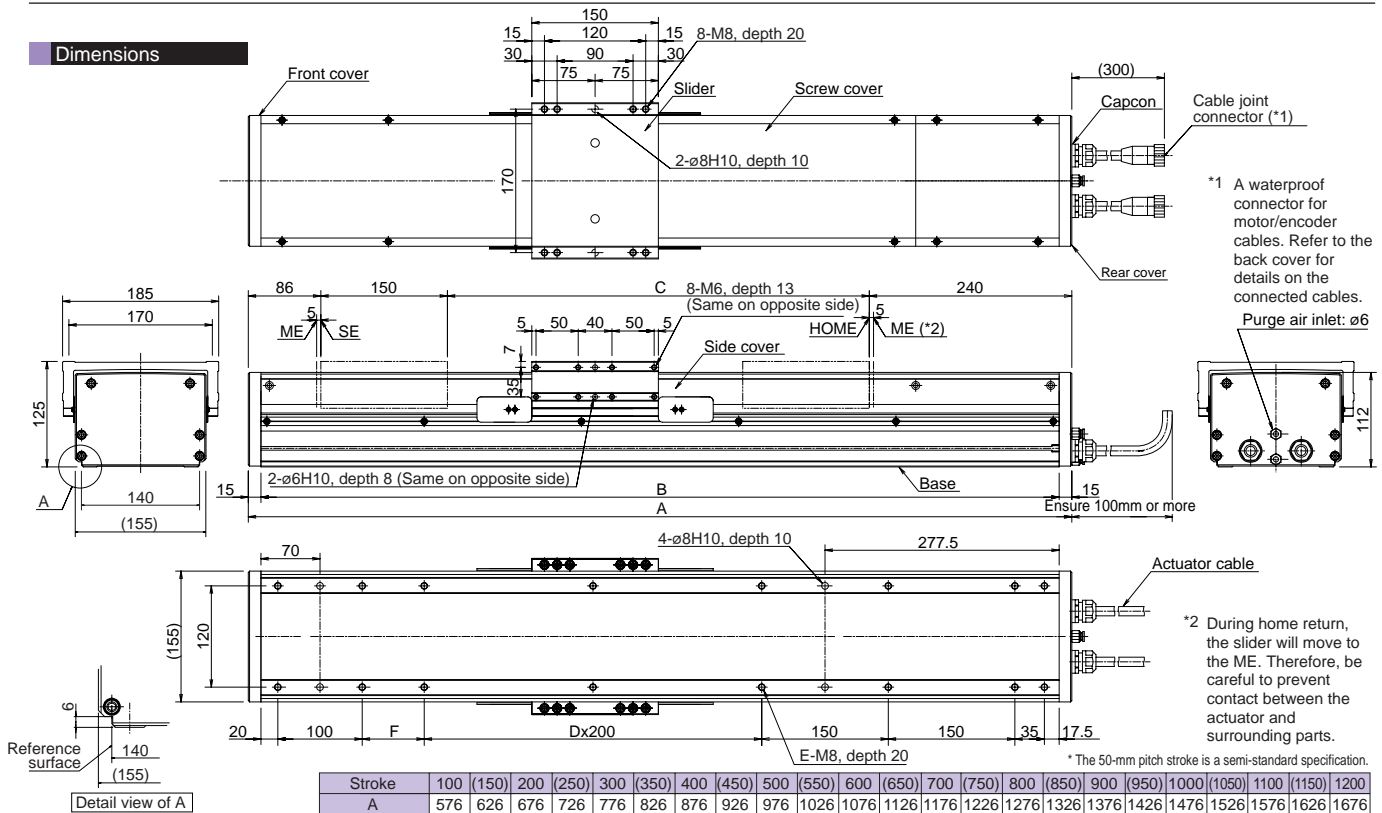

\*1 A waterproof connector for motor/encoder cables. Refer to the back cover for details on the connected cables.

\*2 During home return, the slider will move to the ME. Therefore, be careful to prevent contact between the actuator and surrounding parts.

\* The 50-mm pitch stroke is a semi-standard specification.

Stroke	100	(150)	200	(250)	300	(350)	400	(450)	500	(550)	600	(650)	700	(750)	800	(850)	900	(950)	1000	(1050)	1100	(1150)	1200
A	576	626	676	726	776	826	876	926	976	1026	1076	1126	1176	1226	1276	1326	1376	1426	1476	1526	1576	1626	1676
B	546	596	646	696	746	796	846	896	946	996	1046	1096	1146	1196	1246	1296	1346	1396	1446	1496	1546	1596	1646
C	100	150	200	250	300	350	400	450	500	550	600	650	700	750	800	850	900	950	1000	1050	1100	1150	1200
D	—	—	—	1	1	1	1	1	2	2	2	3	3	3	3	4	4	4	4	5	5	5	5
E	12	12	12	14	14	14	14	16	16	16	16	18	18	18	18	20	20	20	20	22	22	22	22
F	73.5	123.5	173.5	223.5	273.5	323.5	373.5	423.5	473.5	523.5	573.5	623.5	673.5	723.5	773.5	823.5	873.5	923.5	973.5	1023.5	1073.5	1123.5	1173.5
Weight (kg)	20.1	20.6	22.0	22.5	23.9	24.4	25.8	26.3	27.7	28.2	29.6	30.1	31.5	32.0	33.4	33.9	35.3	35.8	37.2	37.7	39.1	39.6	41.0

Maximum speed (mm/s)  
\* Varies depending on the stroke.

Lead	20	1000	930	765	640	545	465
------	----	------	-----	-----	-----	-----	-----

## Applicable Controller Specifications

Applicable controller	Maximum number of controlled axes	Compatible encoder type	Operating method	Power-supply voltage
X-SEL	6 axes	Absolute/incremental	Programming	AC100V
E-Con	1 axis	Absolute/incremental	Positioner	AC200V
P-Driver	1 axis	Incremental	Pulse-train control	

**Caution**  
(Note 1) A longer stroke will result in a lower maximum speed to prevent the ball screw from reaching a dangerous speed. (Refer to the above table for the maximum speed at a given stroke.)  
(Note 2) Based on an acceleration of 0.3 G.  
(Note 3) The figures in square brackets apply to the ISPWA series.  
(Note 4) The maximum cable length is 30 m. Specify the desired length in meters (e.g., X08 = 8 m).  
(Note 5) IP65 applies when air purge is performed. Without air purge, the protection class is IP54.  
The ISWA/ISPWA must be installed horizontally. If the actuator is installed on its side or oriented vertically, water may enter the interior.

## Controller

A controller of one of three types—programming type, positioner type and pulse-train input type—can be selected according to your specific control needs.

\* Refer to the separate catalog for the details of each controller.

### Programming Type

#### [X-SEL Controller]

A high-function, multi-axis controller equipped with Super SEL, a programming language that allows for easy programming of complex operations.

- [Features]
- Simultaneous control of up to 6 axes
  - Registration of up to 64 programs/3,000 positions
  - Absolute or incremental specification
  - Supporting DeviceNet, CC-Link, ProfiBus and Ethernet
  - CE Mark certification



### Positioner Type

#### [E-Con Controller]

A simple single-axis positioner. All you need is to register coordinates in position numbers and specify desired numbers via PIO.

- [Features]
- Maximum 64 positioning points
  - Absolute or incremental specification
  - Supporting DeviceNet, CC-Link and ProfiBus
  - CE Mark certification



### Pulse-Train Input Type

#### [P-Driver]

You can freely control the actuator based on pulse-train input.

- [Features]
- Pulse-train input means unlimited positioning points are accommodated
  - Dedicated home-return signal
  - Torque-limiting function (push & hold operation)
  - Feedback-pulse output function



## Motor/Encoder Cables

\* Enter the desired cable length up to 30 m (L) in . Example:080 = 8 m

### Motor Cable (Splash-Proof Specification) for XSEL-J/K/P/Q, E-Con and P-Driver [Model: CB-XEU-MA□□□]

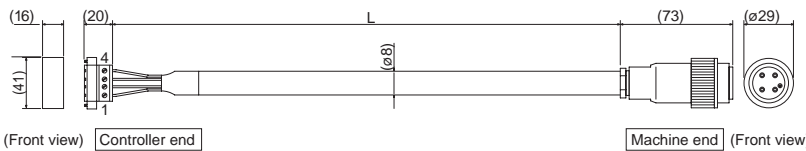

#### Wiring Diagram

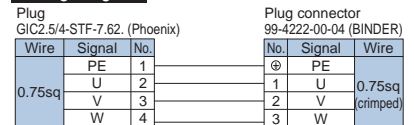

### Encoder Cable (Splash-Proof Specification) for XSEL-J/K, E-Con and P-Driver [Model: CB-X-PA□□□-WC]

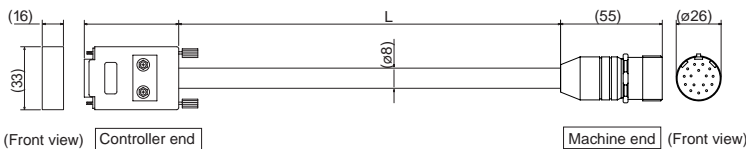

#### Wiring Diagram

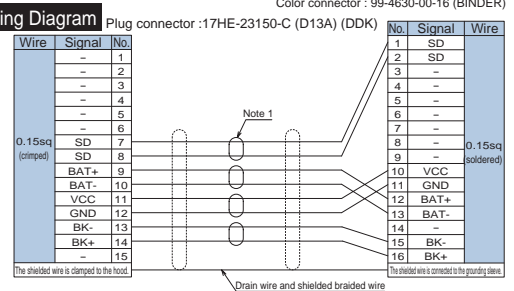

### Encoder Cable (Splash-Proof Specification) for XSEL-P/Q [Model: CB-X1-PA□□□-WC]

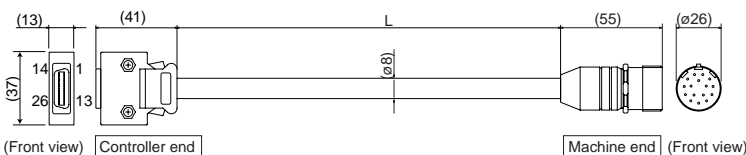

#### Wiring Diagram

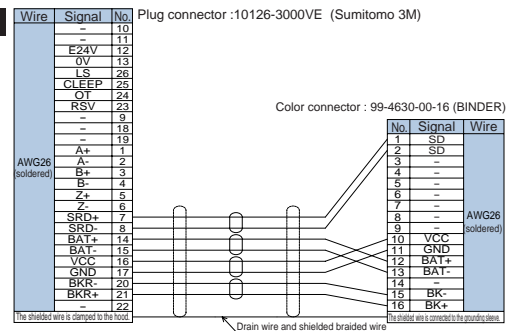

**IAI America, Inc.**  
Head Office 2690W 237th Street Torrance CA 90505  
TEL: 1-800-736-1712  
Chicago Office: 1261 Hamilton Parkway Itasca, IL 60143  
TEL: 1-800-944-0333  
New Jersey Office: 7 South Main Street, Suite-F, Marlboro, NJ 07746  
TEL: 1-877-683-4500  
Website: www.Intelligentactuator.com

**IAI Industrieroboter GmbH**  
Ober der Röh 4, D-65824 Schwalbach am Taunus, Germany

