

Quick Fitting Type Vacuum Filter

Vacuum Filter

Features

- Using the element and cyclone effect, the Vacuum Filter removes the dust and waterdrops sucked in by the Vacuum Generator.
- The large dust case reduces the frequency of maintenance.
- As the whole dust case can be removed in a snap, dust is not scattered.

Specifications

Fluid admitted	Air
Service pressure range	-29.5in. Hg(-100KPa)
Filtering accuracy	10μm
Service temperature range	0~60°C

Model Designatin (Example)

VFB
20
=
6
=
6
=
W

(1) Type

(2) Filter size

Code	2	3	15	20	30
Filtering area	7.5cm ² 1.16in. ²	12.5cm ² 1.94in. ²	1.7cm ² 0.26in. ²	20cm ² 3.10in. ²	7cm ² 1.09in. ²

(3) IN-side tube dia

Code	6	8	10	12	16	M4	M6
dia. (mm)	φ6	φ8	φ10	φ12	φ16	M4×0.7	M6×1
Code	5/32	3/16	1/4	5/16	3/8	1/2	5/8
in. size	φ5/32	φ3/16	φ1/4	φ5/16	φ3/8	φ1/2	φ5/8

(4) OUT-side tube dia

Code	6	8	10	12	16		
dia. (mm)	φ6	φ8	φ10	φ12	φ16		
Code	5/32	3/16	1/4	5/16	3/8	1/2	5/8
in. size	φ5/32	φ3/16	φ1/4	φ5/16	φ3/8	φ1/2	φ5/8

(5) Color

W : Ivory
No code : Black (VFU only)

No code : open to atmosphere type (VFR only)

Example of piping

- ⚠ Caution ■ Installed between the Vacuum Pad and the Vacuum Generator, the filter removes dust and dirt having entered from the pad and thus prevents troubles of the Vacuum Generator.

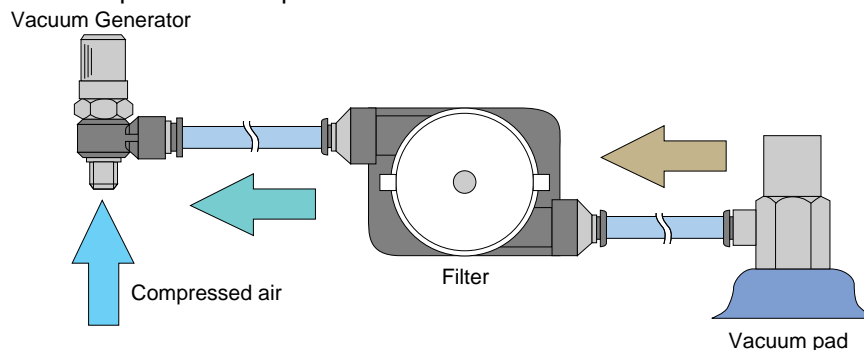

- The open-to-the-air type VFR is to be used, installed on the exhaust side of the VRL type Vacuum Generator for particle or powder conveyance.

*Contact us in case of particle transfer.

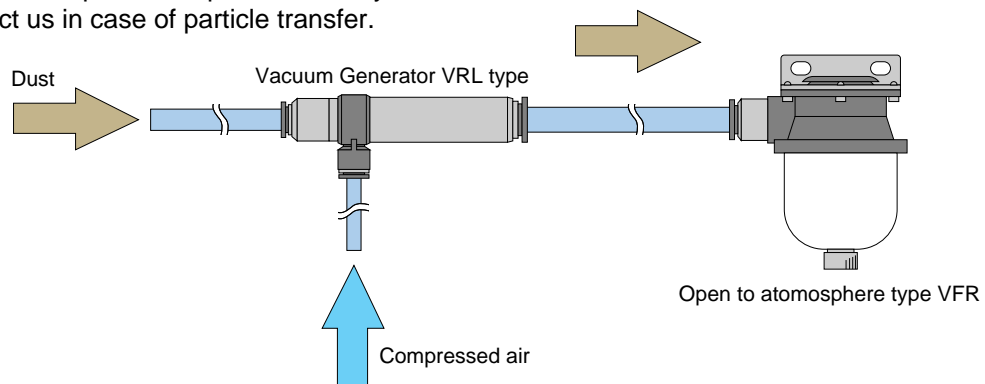

⚠ Detail Safety Instructions

Before using the PISCO device, be sure to read the "Safety Instruction", "Common Safety Instructions for Products Listed in This Manual" on pages 23~24 and "Common Safety Instructions for Vacuum" on pages 379~380.

⚠ Warning

1. Never apply positive pressure for vacuum release to the VFB or VFR type Vacuum Filter. They are not explosion-proof and their pressure resistance is low. Damage to the filter body may cause injuries on you.
2. Conduct periodic maintenance and checks of the filter element of the Vacuum Filter. Clogging of the element may cause performance drop or trouble. For the replacement of the element, observe the instructions on dust removal and element replacement for Vacuum Generator in the manual, allow the internal pressure of the filter to become the atmospheric pressure, and then carry out the replacement after confirming safety.

⚠ Caution

1. Make sure that the operation environment of the Vacuum Filter meets the requirements in the "Common Safety Instructions for Vacuum".
2. Connect piping upon confirming the IN and OUT in the manual and marks on the product. Reverse connection will result in a functional failure of the Filter.
3. Remove dust and replace the element. Then fix the case securely and make certain that there is no vacuum leak.

Vacuum Series Vacuum Filter

VFB

Large Capacity Union Type

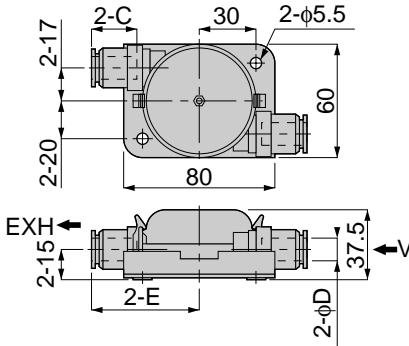
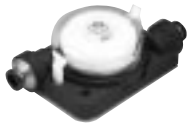

unit:mm

Model	Tube dia. φD	C	E	Filtering area (mm ²)	Mass (g)
VFB 20-6-6	6	17	56.5	20	206
VFB 20-8-8	8	18.5	56.5		204.5
VFB 20-10-10	10	21	57		198
VFB 20-12-12	12	23.5	56.5		190.5
VFB 20-16-16	16	25	64		231.5

※ Spare element : VFE 20



VFR

Large Capacity Union Type

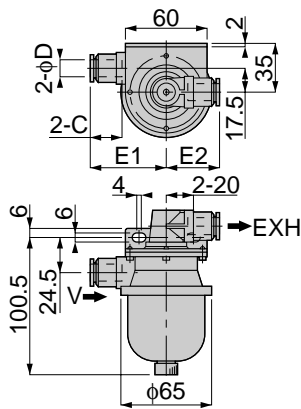

unit:mm

Model	Tube dia. φD	C	E1	E2	Filtering area (mm ²)	Mass (g)
VFR 20-6-6	6	17	48	38	20	232
VFR 20-8-8	8	18.5	48	38		230.5
VFR 20-10-10	10	21	48.5	38.5		224.5
VFR 20-12-12	12	23.5	48	38		217
VFR 20-16-16	16	25	55.5	43.5		240

※ Spare element : VFE 20



VFR

Large Capacity Open to atmosphere Type

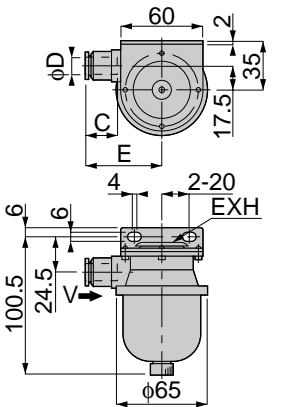

unit:mm

Model	Tube dia. φD	C	E	Filtering area (mm ²)	Mass (g)
VFR 20-6	6	17	48	20	195.5
VFR 20-8	8	18.5	48		194.5
VFR 20-10	10	21	48.5		191.5
VFR 20-12	12	23.5	48		187.5
VFR 20-16	16	25	55.5		199

※ Spare element : VFE 20



VFU

Small Union Type



IN(pad side)

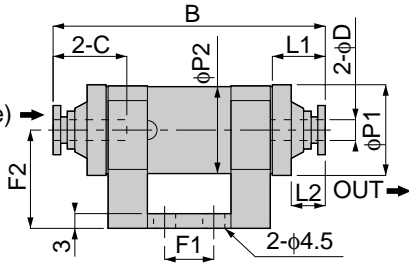

unit:mm

Model	Tube dia. φD	B	L1	L2	φP1	φP2	C	F1	F2	Filtering area (mm ²)	Mass (g)
VFU 2-44	4	55	10.5	6.5	18.5	17.5	15	10	20	7.5	23.5
VFU 2-66	6	58	12	7	22.5	21.5	16.5				25
VFU 3-66	6	66	13	8			16.5	14	24	12.5	39
VFU 3-88	8	67.5	13.5	7.5	17.5	39.5					
VFU 3-1010	10	75	17	6	20	47					

※ Spare element : VFU 2-□□ : VFE 2
VFU 3-□□ : VFE 3



VFF

Pad Direct-Mounting Type

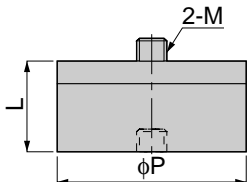

unit:mm

Model	M	L	φP	Filtering area (mm ²)	Mass (g)
VFF 15-M4	M4×0.7	12	25	1.7	13.5
VFF 15-M6	M6×1				14
VFF 30-M6	M6×1	15	40	7	37.5

※ Spare element : VFF 15-□□ : VFFE 15
VFF 30-□□ : VFFE 30

