

Quick-fitting Type Ejector Vacuum Generator VRL

Features

- Vacuum generator of this type convey small, irregular materials, such as particles, powder and fibers on the air current.
- The suction port and the exhaust port are located in a straight line. The works sucked in from the suction port pass through the inside of the vacuum generator and go out of the exhaust port. Thus the vacuum generator enables conveyance of works through a tube.
- An optimal vacuum generator can be selected according to the work size and quantity.

Specification

Fluid admitted	Air, Inert gas	
Service pressure range	0~150psi	0~0.9MPa
Rated supply pressure	71.1psi	0.5MPa
Service temperature range	32~140°F	0~60°C

Construction

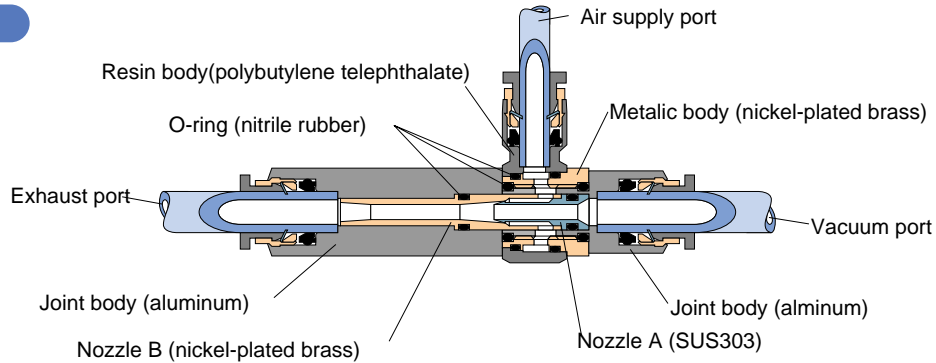

Model Designation (Example)

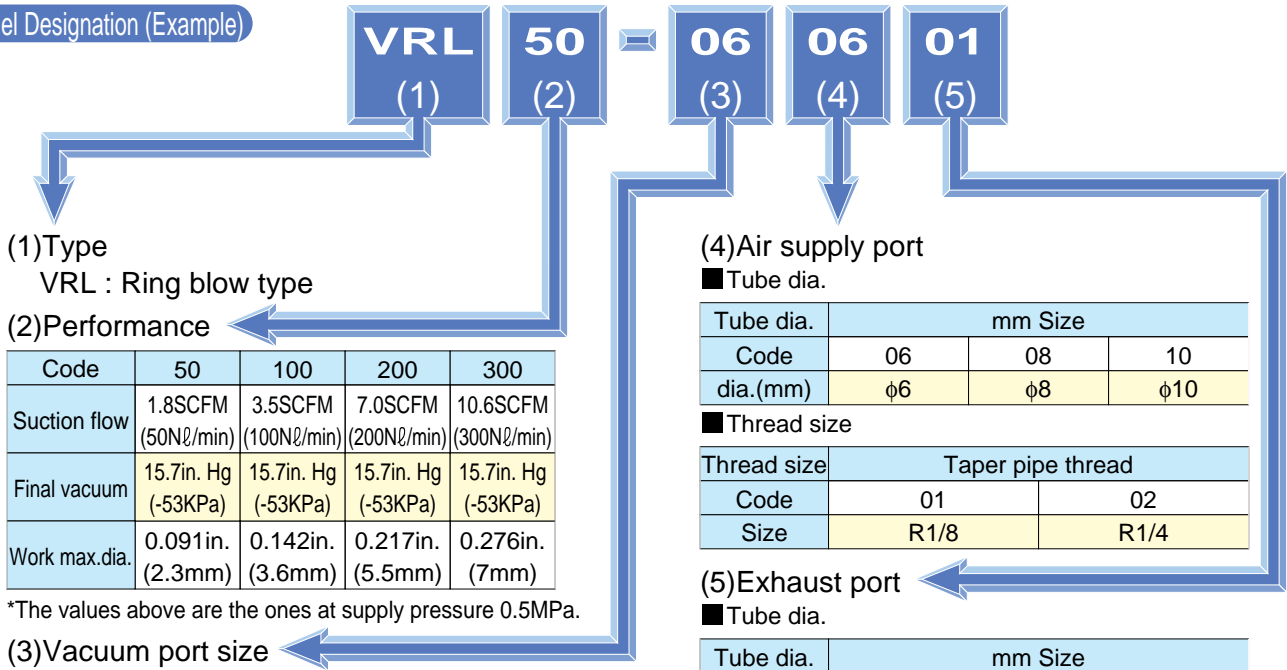

(1) Type
VRL : Ring blow type

(2) Performance

Code	50	100	200	300
Suction flow	1.8SCFM (50Nℓ/min)	3.5SCFM (100Nℓ/min)	7.0SCFM (200Nℓ/min)	10.6SCFM (300Nℓ/min)
Final vacuum	15.7in. Hg (-53KPa)	15.7in. Hg (-53KPa)	15.7in. Hg (-53KPa)	15.7in. Hg (-53KPa)
Work max.dia.	0.091in. (2.3mm)	0.142in. (3.6mm)	0.217in. (5.5mm)	0.276in. (7mm)

*The values above are the ones at supply pressure 0.5MPa.

(3) Vacuum port size

■ Tube dia.

Tube dia.	mm Size				
Code	6	8	10	12	16
Size(mm)	φ6	φ8	φ10	φ12	φ16

■ Thread size

Thread size	Taper pipe thread			
Code	01	02	03	04
Size	R1/8	R1/4	R3/8	R1/2

(4) Air supply port

■ Tube dia.

Tube dia.	mm Size		
Code	06	08	10
dia.(mm)	φ6	φ8	φ10

■ Thread size

Thread size	Taper pipe thread	
Code	01	02
Size	R1/8	R1/4

(5) Exhaust port

■ Tube dia.

Tube dia.	mm Size		
Code	08	12	16
dia.(mm)	φ8	φ12	φ16

■ Thread size

Thread size	Taper pipe thread		
Code	01	02	04
Size	R1/8	R1/4	R1/2

⚠ Detailed Safety Instruction

Before using the PISCO device, be sure to read the "Safety Instructions", "Common Safety Instructions for Products Listed in This Manual" on pages 23~24 and "Common Safety Instructions for Vacuum" on pages 379~380.

⚠ Caution

1. VRL can not transport particles, powder or fiber materials under certain conditions. Contact PISCO for information.

Vacuum Series Vacuum Generator VRL Type

VRL

Nipple Type A

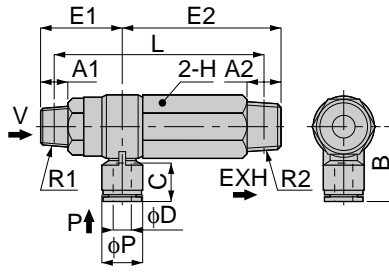

unit:mm

Model	Tube dia. φD	R1	R2	A1	A2	B	L	φP	C	E1	E2	H	*1 (mm)	*2 (-KPa)	*3 (Nℓ/min)	*4 (mm)	*5 (Nℓ/min)	Mass (g)
VRL 50-010601	6	R1/8	R1/8	8	8	25	51	12.5	16.5	23	36	14	3	53	50	2.3	50	41
VRL 50-010801	8					28.5		14.5	17.5									42.5
VRL 100-020802	8	R1/4	R1/4	11	11	29	70	14.5	17.5	29.5	53	17	4	53	100	3.6	100	81
VRL 100-021002	10					31.5		17.5	20									84
VRL 200-031004	10	R3/8	R1/2	12	15	34	90	17.5	20	35	69.5	22	6	53	200	5.5	200	190
VRL 200-041004		R1/2		15						38		24						204
VRL 300-031004	10	R3/8	R1/2	12	15	34	90	17.5	20	35	69.5	22	7.5	53	300	7	300	179
VRL 300-041004		R1/2		15						38		24						193

*1 Nozzle dia. *2 Final vacuum *3 Suction flow *4 Works max. dia. *5 Air consumption.

VRL

Nipple Type B

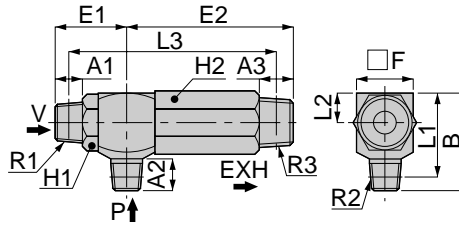

unit:mm

Model	R1	R2	R3	A1	A2	A3	B	L1	L2	L3	E1	E2	H1	H2	□F	*1 (mm)	*2 (-KPa)	*3 (Nℓ/min)	*4 (mm)	*5 (Nℓ/min)	Mass (g)
VRL 50-010101	R1/8	R1/8	R1/8	8	8	8	28	24	8	51	21	38	14	14	16	3	53	50	2.3	50	36.5
VRL 100-020202	R1/4	R1/4	R1/4	11	11	11	35	29	10	70	27	55	17	17	20	4	53	100	3.6	100	78.5
VRL 200-030204	R3/8	R1/4	R1/2	12	11	15	42.5	36.5	12.5	90	31.5	73	22	24	24	6	53	200	5.5	200	180
VRL 200-040204	R1/2			15									91.5								34.5
VRL 300-030204	R3/8	R1/4	R1/2	12	11	15	42.5	36.5	12.5	90	31.5	73	22	24	24	7.5	53	300	7	300	169.5
VRL 300-040204	R1/2			15									91.5								34.5

*1 Nozzle dia. *2 Final vacuum *3 Suction flow *4 Works max. dia. *5 Air consumption.

VRL

Straight A

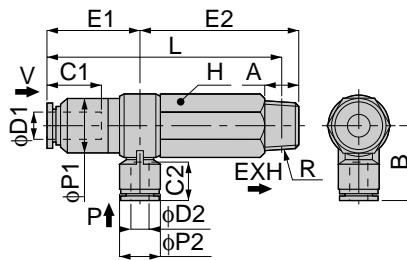

unit:mm

Model	Tube dia. φD1	Tube dia. φD2	R	A	B	L	φP1	φP2	C1	C2	E1	E2	H	*1 (mm)	*2 (-KPa)	*3 (Nℓ/min)	*4 (mm)	*5 (Nℓ/min)	Mass (g)
VRL 50-060601	6	6	R1/8	8	25	16	12.5	16.5	16.5	29	36	14	3	53	50	2.3	50	38	
VRL 50-080601	8				62													17.5	30
VRL 50-060801	6	8	R1/8	8	28.5	20	14.5	16.5	17.5	27	53	17	4	53	100	3.6	100	39.5	
VRL 50-080801	8				60													17.5	28
VRL 100-100802	10	8	R1/4	11	29	20	14.5	20	17.5	35.5	53	17	4	53	100	3.6	100	77	
VRL 100-120802	12				85													23.5	38
VRL 100-101002	10	10	R1/4	11	31.5	20	17.5	20	20	35.5	53	17	4	53	100	3.6	100	80	
VRL 100-121002	12				85													23.5	38
VRL 200-121004	12	10	R1/2	15	34	25	17.5	23.5	20	43.5	69.5	24	6	53	200	5.5	200	182	
VRL 200-161004	16				106.5													25	20
VRL 300-121004	12	10	R1/2	15	34	25	17.5	23.5	20	43.5	69.5	24	7.5	53	300	7	300	171.5	
VRL 300-161004	16				106.5													25	20

*1 Nozzle dia. *2 Final vacuum *3 Suction flow *4 Works max. dia. *5 Air consumption.

Vacuum Series Vacuum Generator VRL Type

VRL

Straight B

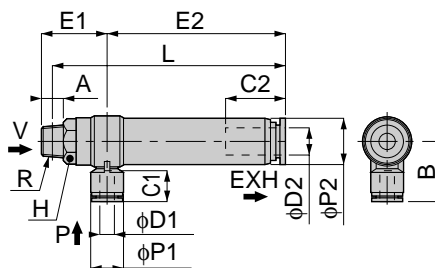

unit:mm

Model	Tube dia. φD1	Tube dia. φD2	R	A	B	L	φP1	φP2	C1	C2	E1	E2	H	*1 (mm)	*2 (-KPa)	*3 (Nℓ/min)	*4 (mm)	*5 (Nℓ/min)	Mass (g)
VRL 50-010608	6	8	R1/8	8	25	74	12.5	16	16.5	17.5	23	55	14	3	53	50	2.3	50	52
VRL 50-010808	8				28.5	73	14.5		17.5	22	53.5								
VRL 100-020812	8	12	R1/4	11	29	100	14.5	20	17.5	23.5	29.5	76.5	17	4	53	100	3.6	100	105
VRL 100-021012	10				31.5	100	17.5		20	23.5	29.5								76.5
VRL 200-031016	10	16	R3/8	12	34	103	17.5	25	20	25	35	74.5	22	6	53	200	5.5	200	194
VRL 200-041016			R1/2	15		104.5					38								24
VRL 300-031016	10	16	R3/8	12	34	103	17.5	25	20	25	35	74.5	22	7.5	53	300	7	300	183.5
VRL 300-041016			R1/2	15		104.5					38								24

*1 Nozzle dia. *2 Final vacuum *3 Suction flow *4 Works max. dia. *5 Air consumption.

VRL

Straight C

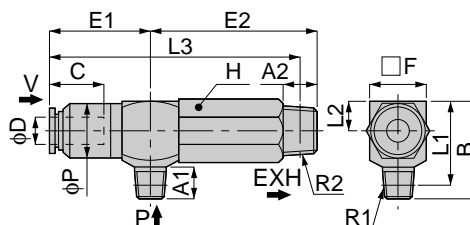

unit:mm

Model	Tube dia. φD	R1	R2	A1	A2	B	L1	L2	L3	φP	C	E1	E2	H	□F	*1 (mm)	*2 (-KPa)	*3 (Nℓ/min)	*4 (mm)	*5 (Nℓ/min)	Mass (g)
VRL 50-060101	6	R1/8	R1/8	8	8	28	24	8	61	16	16.5	27	38	14	16	3	53	50	2.3	50	34
VRL 50-080101	8								62		28	33.5									
VRL 100-100202	10	R1/4	R1/4	11	11	35	29	10	83	20	20	34	55	17	20	4	53	100	3.6	100	75
VRL 100-120202	12								84.5		23.5	35.5									76
VRL 200-120204	12	R1/4	R1/2	11	15	42.5	36.5	12.5	105	25	23.5	40	73	24	25	6	53	200	5.5	200	172
VRL 200-160204	16								106.5		25	41.5									173.5
VRL 300-120204	12	R1/4	R1/2	11	15	42.5	36.5	12.5	105	25	23.5	40	73	24	25	7.5	53	300	7	300	161.5
VRL 300-160204	16								106.5		25	41.5									162.5

*1 Nozzle dia. *2 Final vacuum *3 Suction flow *4 Works max. dia. *5 Air consumption.

VRL

Straight D

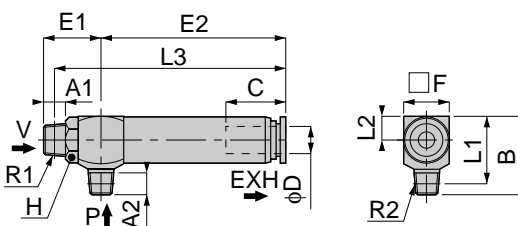

unit:mm

Model	Tube dia. φD	R1	R2	A1	A2	B	L1	L2	L3	C	E1	E2	H1	□F	*1 (mm)	*2 (-KPa)	*3 (Nℓ/min)	*4 (mm)	*5 (Nℓ/min)	Mass (g)
VRL 50-010108	8	R1/8	R1/8	8	8	28	24	8	74	17.5	21	57	14	16	3	53	50	2.3	50	48.5
VRL 100-020212	12	R1/4	R1/4	11	11	35	29	10	99.5	23.5	27	78.5	17	20	4	53	100	3.6	100	102.5
VRL 200-030216	16	R3/8	R1/4	12	11	42.5	36.5	12.5	103	25	31.5	78	22	25	6	53	200	5.5	200	184.5
VRL 200-040216		R1/2		15					104.5		34.5									24
VRL 300-030216	16	R3/8	R1/4	12	11	42.5	36.5	12.5	103	25	31.5	78	22	25	7.5	53	300	7	300	173.5
VRL 300-040216		R1/2		15					104.5		34.5									24

*1 Nozzle dia. *2 Final vacuum *3 Suction flow *4 Works max. dia. *5 Air consumption.



1



2



1



2



1

Vacuum Series Vacuum Generator VRL Type

VRL

Union Straight A

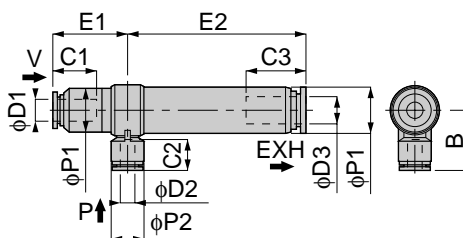

unit:mm

Model	Tube dia. φD1	Tube dia. φD2	Tube dia. φD3	B	φP1	φP2	C1	C2	C3	E1	E2	*1 (mm)	*2 (-KPa)	*3 (Nℓ/min)	*4 (mm)	*5 (Nℓ/min)	Mass (g)
VRL 50-060608	6	6	8	25	16	12.5	16.5	17.5	17.5	29	55	3	53	50	2.3	50	49
VRL 50-060808		8		28.5		14.5	17.5			27.5							50.5
VRL 50-080608	8	6	8	25	16	12.5	16.5	17.5	17.5	30	55	3	53	50	2.3	50	49
VRL 50-080808		8		28.5		14.5	17.5			28.5							50.5
VRL 100-100812	10	8	12	29	20	14.5	20	23.5	23.5	35.5	76.5	4	53	100	3.6	100	101.5
VRL 100-120812	12			23.5		17.5	38			103							
VRL 100-101012	10	10	12	31.5	20	17.5	20	23.5	23.5	35.5	76.5	4	53	100	3.6	100	104.5
VRL 100-121012	12			23.5		20	38			106							
VRL 200-121016	12	10	16	34	25	17.5	23.5	20	25	43.5	74.5	6	53	200	5.5	200	186
VRL 200-161016	16			25		20	25			45							187
VRL 300-121016	12	10	16	34	25	17.5	23.5	20	25	43.5	74.5	7.5	53	300	7	300	175.5
VRL 300-161016	16			25		20	25			45							176.5

*1 Nozzle dia. *2 Final vacuum *3 Suction flow *4 Works max. dia. *5 Air consumption.

VRL

Union Straight B

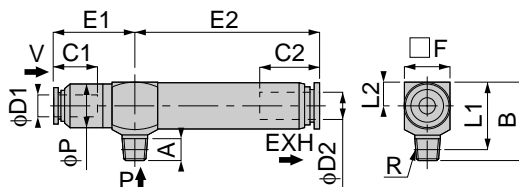

unit:mm

Model	Tube dia. φD1	Tube dia. φD2	R	A	B	L1	L2	φP	C1	C2	E1	E2	□F	*1 (mm)	*2 (-KPa)	*3 (Nℓ/min)	*4 (mm)	*5 (Nℓ/min)	Mass (g)
VRL 50-060108	6	8	R1/8	8	28	24	8	16	16.5	17.5	27	57	16	3	53	50	2.3	50	45
VRL 50-080108	8								17.5		28								44.5
VRL 100-100212	10	12	R1/4	11	35	29	10	20	20	23.5	34	78.5	20	4	53	100	3.6	100	99
VRL 100-120212	12								23.5		35.5								106
VRL 200-120216	12	16	R1/4	11	42.5	36.5	12.5	25	23.5	25	40	78	25	6	53	200	5.5	200	176.5
VRL 200-160216	16								25		41.5								177.5
VRL 300-120216	12	16	R1/4	11	42.5	36.5	12.5	25	23.5	25	40	78	25	7.5	53	300	7	300	166
VRL 300-160216	16								25		41.5								167

*1 Nozzle dia. *2 Final vacuum *3 Suction flow *4 Works max. dia. *5 Air consumption.

Characteristics

Supply pressure-Final vacuum, Suction flow, Air consumption

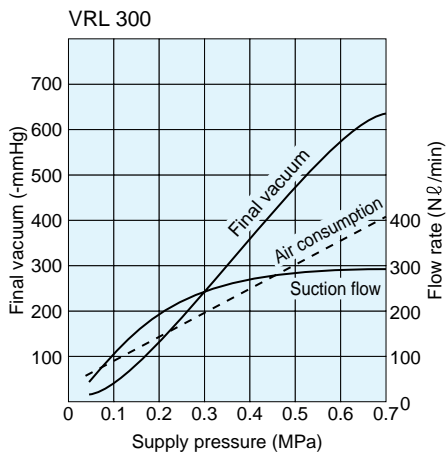
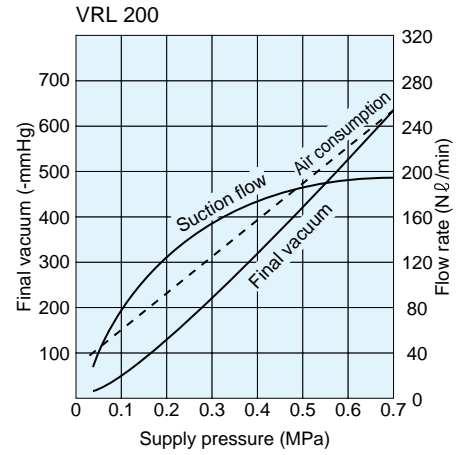
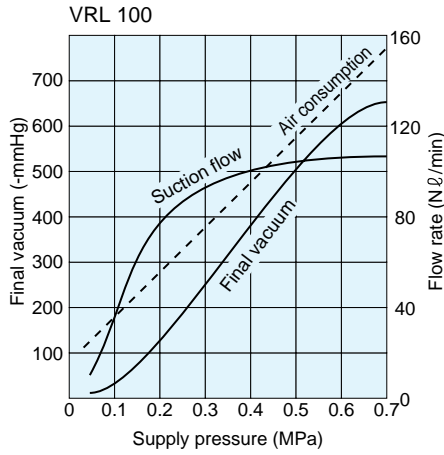
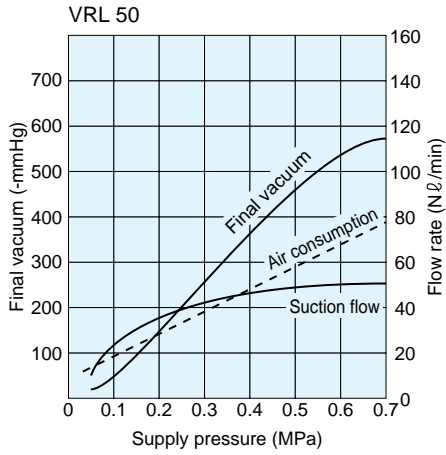

※ The above data are measured values under zero pipe friction condition. They are not guaranteed values since performance decreases under the existence of pipe friction at the exhaust side.