

Quick-fitting Type Shut-off Valve (Residual Pressure Release Valve)

Hand Valve

Features

- The Hand Valve turns on and off air pressure to pneumatic devices.
- The three-directional control valve, when closed, discharges the residual pressure from the output side (device). The two-directional control valve does not have air discharge mechanism.
- Hand Valves come in four types for your applications.

Construction

2-way valve
Graphical representation

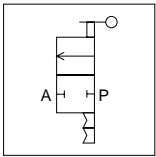

3-way valve
Graphical representation

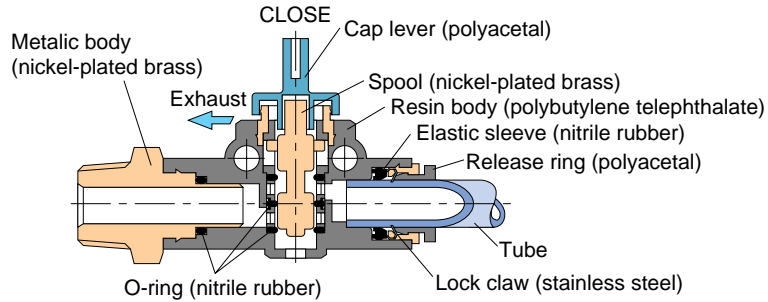
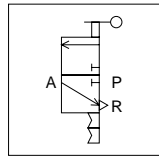

Specification

Fluid admitted	Air	
Service pressure range	0~150psi	0~0.9MPa
Working vacuum	-29.5in. Hg	-100KPa
Service temperature range	32~140°F	0~60°C

Model Designation (example)

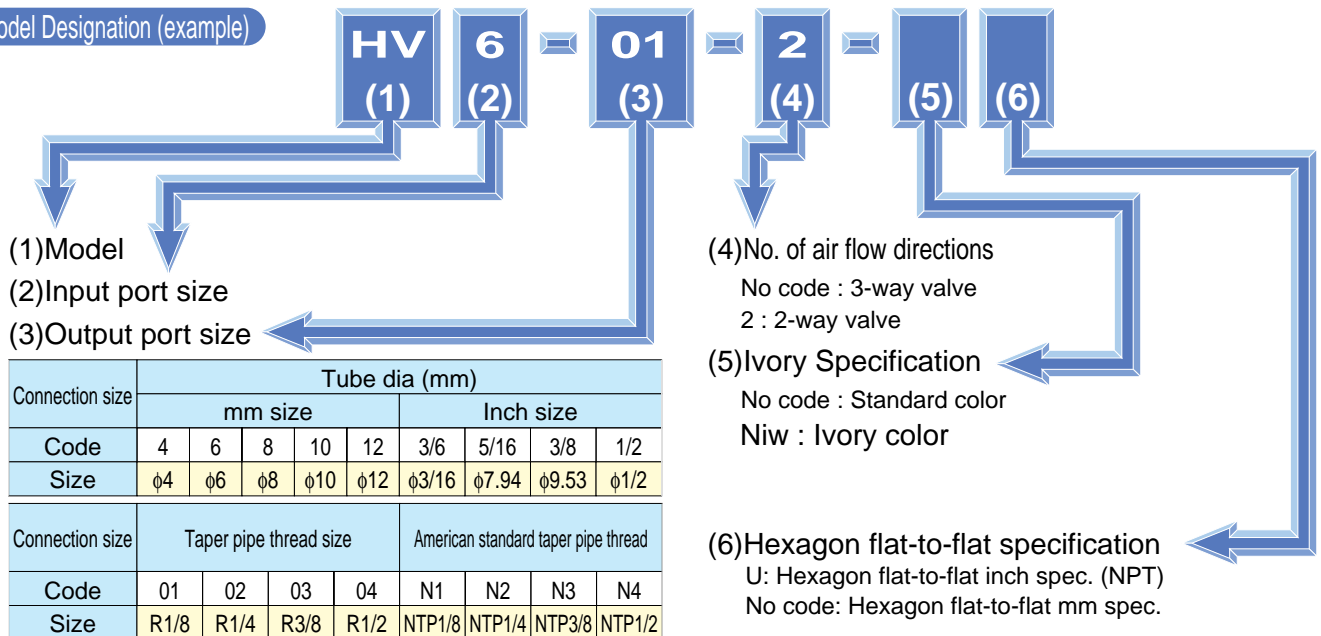

About 3-way and 2-way Valves

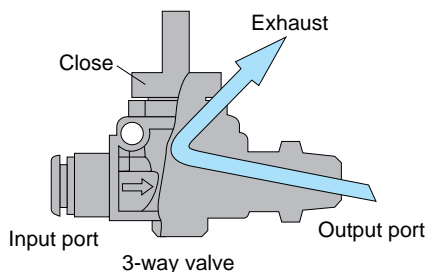

- The three-directional control valve, when air is stopped, discharges the residual pressure from the output side (connected devices). Therefore it assures safety at adjustment or repair of the connected devices. The two-directional control valve, which does not discharge the residual pressure, is suited for air supply to a tank or other devices from which the residual pressure should not be discharged. The two-directional control valve is also suited for the system where vacuum piping is used.

⚠ Detailed Safety Instructions

Before using the PISCO device, be sure to read the "Safety Instructions", "Common Safety Instructions for Products Listed in This Manual" on page 23-24 and "Common Safety Instructions for Change Series Valves" on page 279.

⚠ Caution

1. When operating the cap lever, turn it 90 degrees completely until it stops. Inadequate turning may result in poor conduction or low flow rate due to faulty switching.
2. Distinguish between the two-directional and the three-directional control valve by checking the marking ② or ③ on the top surface of the cap lever.
3. For use with negative pressures, provide a vacuum filter on the suction side. Otherwise dust sucked in may cause malfunction.

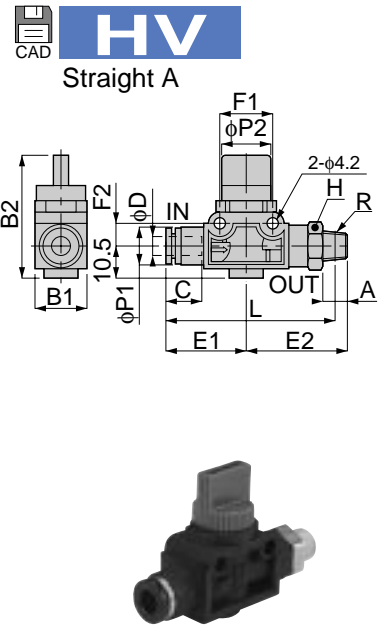

unit:mm

Model	Tube dia φD	R	A	B1	B2	L	φP1	φP2	C	E1	E2	H	F1	F2	Mass (g)	Orifice dia. (φmm)	Eff. Area (mm ²)
HV 6-01-□-□	6	R1/8	8		55.5						33.5				33		7.5
HV 6-02-□-□		R1/4	11	17	40.5	56.5	12.5	16.5	17	26	36.5	14	18	8	39.5	5	7.7
HV 6-03-□-□		R3/8	12			58						38.5	17		52		7.5
HV 8-01-□-□	8	R1/8	8		57.5						33.5				34.5		8.7
HV 8-02-□-□		R1/4	11	17	40.5	58.5	15	16.5	18	28	36.5	14	18	8	40.5	5	8.9
HV 8-03-□-□		R3/8	12			60						38.5	17		53.5		8.6
HV 10-02-□-□	10	R1/4	11		69						42.5				61.5		16.2
HV 10-03-□-□		R3/8	12	21	41	69.5	17.5	19.5	20	32.5	43.5	17	24	11	70	7	16
HV 10-04-□-□		R1/2	15			71						46.5	21		91.5		15.7
HV 12-02-□-□	12	R1/4	11		71.5						42.5				65		16.3
HV 12-03-□-□		R3/8	12	21	41	72	21	19.5	23.5	35	43.5	17	24	11	73	7	16.3
HV 12-04-□-□		R1/2	15			73.5						46.5	21		95		16.1
HV 1/4-01-□-□	1/4	R1/8	8		55.5						33.5				33		8.2
HV 1/4-02-□-□		R1/4	11	17	40.5	56.5	12.5	16.5	17	26	36.5	14	18	8	39.5	5	8
HV 1/4-03-□-□		R3/8	12			58						38.5	17		52		8.2
HV 5/16-01-□-□	5/16	R1/8	8		57.5						33.5				34.5		8.7
HV 5/16-02-□-□		R1/4	11	17	40.5	58.5	15	16.5	18	28	36.5	14	18	8	40.5	5	8.9
HV 5/16-03-□-□		R3/8	12			60						38.5	17		53.5		8.6
HV 3/8-02-□-□	3/8	R1/8	11		69						42.5				61.5		15.4
HV 3/8-03-□-□		R3/8	12	21	41	69.5	17.5	19.5	20	32.5	43.5	17	24	11	70	7	15.7
HV 3/8-04-□-□		R1/2	15			71						46.5	21		91.5		15.4

unit:inch

MODEL	Tube dia. φ	NPT	A	B	C	E1	E2	F1	F2	W	H	Weight (g)	Orifice φmm	Eff. A. mm ²	Cv
HV3/16-N1U	3/16	1/8	0.31	1.59	0.67	1.02	1.16	0.71	0.31	0.67	9/16	33.7	4.0	5.1	0.27
HV3/16-N2U	3/16	1/4	0.43	1.59	0.67	1.02	1.20	0.71	0.31	0.67	9/16	39.6	4.0	5.1	0.27
HV3/16-N3U	3/16	3/8	0.47	1.59	0.67	1.02	1.26	0.71	0.31	0.67	11/16	53.3	4.0	5.2	0.28
HV1/4-N1U	1/4	1/8	0.31	1.59	0.67	1.02	1.16	0.71	0.31	0.67	9/16	33.8	5.0	7.5	0.40
HV1/4-N2U	1/4	1/4	0.43	1.59	0.67	1.02	1.20	0.71	0.31	0.67	9/16	39.8	5.0	7.7	0.41
HV1/4-N3U	1/4	3/8	0.47	1.59	0.67	1.02	1.26	0.71	0.31	0.67	11/16	53.3	5.0	7.5	0.40
HV5/16-N1U	5/16	1/8	0.31	1.59	0.71	1.10	1.16	0.71	0.31	0.83	9/16	34.8	5.0	8.7	0.47
HV5/16-N2U	5/16	1/4	0.43	1.59	0.71	1.10	1.20	0.71	0.31	0.83	9/16	40.7	5.0	8.9	0.48
HV5/16-N3U	5/16	3/8	0.47	1.59	0.71	1.10	1.26	0.71	0.31	0.83	11/16	54.4	5.0	8.6	0.46
HV3/8-N2U	3/8	1/4	0.43	1.61	0.79	1.28	1.44	0.94	0.43	0.83	11/16	63.0	5.0	16.2	0.87
HV3/8-N3U	3/8	3/8	0.47	1.61	0.79	1.28	1.46	0.94	0.43	0.83	11/16	71.3	7.0	16.0	0.86
HV3/8-N4U	3/8	1/2	0.59	1.61	0.79	1.28	1.48	0.94	0.43	0.83	7/8	94.3	7.0	15.7	0.85
HV1/2-N2U	1/2	1/4	0.43	1.61	0.93	1.38	1.44	0.94	0.43	0.83	11/16	65.5	7.0	16.3	0.88
HV1/2-N3U	1/2	3/8	0.47	1.61	0.93	1.38	1.46	0.94	0.43	0.83	11/16	73.9	7.0	16.3	0.88
HV1/2-N4U	1/2	1/2	0.59	1.61	0.93	1.38	1.52	0.94	0.43	0.83	7/8	96.8	7.0	16.1	0.87



Straight B

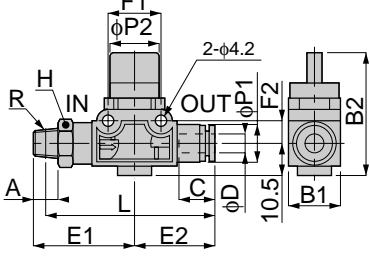

unit:mm

Model	Tube dia. φD	R	A	B1	B2	L	φP1	φP2	C	E1	E2	H	F1	F2	Mass (g)	Orifice (φmm)	Eff. a. (mm ²)
HV 01-6-□-□	6	R1/8	8			55.5				33.5					33		8.3
HV 02-6-□-□		R1/4	11	17	40.5	56.5	12.5	16.5	17	36.5	26	14	18	8	39.5	5	8.5
HV 03-6-□-□		R3/8	12				58				38.5		17			52	
HV 01-8-□-□	8	R1/8	8			57.5				33.5					34.5		8.9
HV 02-8-□-□		R1/4	11	17	40.5	58.5	15	16.5	18	36.5	28	14	18	8	40.5	5	8.9
HV 03-8-□-□		R3/8	12				60				38.5		17			53.5	
HV 02-10-□-□	10	R1/4	11			69				42.5					61.5		16.6
HV 03-10-□-□		R3/8	12	21	41	69.5	17.5	19.5	20	43.5	32.5	17	24	11	70	7	16.9
HV 04-10-□-□		R1/2	15				71				46.5		21			91.5	
HV 02-12-□-□	12	R1/4	11			71.5				42.5					65		17
HV 03-12-□-□		R3/8	12	21	41	72	21	19.5	23.5	43.5	35	17	24	11	73	7	17.1
HV 04-12-□-□		R1/2	15				73.5				46.5		21			95	
HV 01-1/4-□-□	1/4	R1/8	8			55.5				33.5					33		8.7
HV 02-1/4-□-□		R1/4	11	17	40.5	56.5	12.5	16.5	17	36.5	26	14	18	8	39.5	5	8.4
HV 03-1/4-□-□		R3/8	12				58				38.5		17			52	
HV 01-5/16-□-□	5/16	R1/8	8			57.5				33.5					34.5		8.9
HV 02-5/16-□-□		R1/4	11	17	40.5	58.5	15	16.5	18	36.5	28	14	18	8	40.5	5	8.9
HV 03-5/16-□-□		R3/8	12				60				38.5		17			53.5	
HV 02-3/8-□-□	3/8	R1/4	11			69				42.5					61.5		16.5
HV 03-3/8-□-□		R3/8	12	21	41	69.5	17.5	19.5	20	43.5	32.5	17	24	11	70	7	16.8
HV 04-3/8-□-□		R1/2	15				71				46.5		21			91.5	



unit:inch

MODEL	Tube dia. φ	NPT	A	B	C	E1	E2	F1	F2	W	H	Weight (g)	Orifice φmm	Eff. A. mm ²	Cv
HVN1-3/16U	3/16	1/8	0.31	1.59	0.67	1.02	1.16	0.71	0.31	0.67	9/16	34.0	4.0	5.6	0.30
HVN2-3/16U	3/16	1/4	0.43	1.59	0.67	1.02	1.2	0.71	0.31	0.67	9/16	39.8	4.0	6.0	0.32
HVN3-3/16U	3/16	3/8	0.47	1.59	0.67	1.02	1.26	0.71	0.31	0.67	11/16	53.5	4.0	5.7	0.30
HVN1-1/4U	1/4	1/8	0.31	1.59	0.67	1.02	1.16	0.71	0.31	0.67	9/16	33.8	5.0	8.3	0.44
HVN2-1/4U	1/4	1/4	0.43	1.59	0.67	1.02	1.20	0.71	0.31	0.67	9/16	39.5	5.0	8.5	0.46
HVN3-1/4U	1/4	3/8	0.47	1.59	0.67	1.02	1.26	0.71	0.31	0.67	11/16	53.5	5.0	8.2	0.44
HVN1-5/16U	5/16	1/8	0.31	1.59	0.71	1.10	1.16	0.71	0.31	0.83	9/16	35.1	5.0	8.9	0.48
HVN2-5/16U	5/16	1/4	0.43	1.59	0.71	1.10	1.20	0.71	0.31	0.83	9/16	40.9	5.0	8.9	0.48
HVN3-5/16U	5/16	3/8	0.47	1.59	0.71	1.10	1.26	0.71	0.31	0.83	11/16	54.6	5.0	8.9	0.48
HVN2-3/8U	3/8	1/4	0.43	1.61	0.79	1.28	1.44	0.94	0.43	0.83	11/16	63.1	7.0	16.6	0.89
HVN3-3/8U	3/8	3/8	0.47	1.61	0.79	1.28	1.46	0.94	0.43	0.83	11/16	71.3	7.0	16.9	0.91
HVN4-3/8U	3/8	1/2	0.59	1.61	0.79	1.28	1.48	0.94	0.43	0.83	7/8	94.4	7.0	16.5	0.89
HVN2-1/2U	1/2	1/4	0.43	1.61	0.93	1.38	1.44	0.94	0.43	0.83	11/16	65.8	7.0	17.0	0.92
HVN3-1/2U	1/2	3/8	0.47	1.61	0.93	1.38	1.46	0.94	0.43	0.83	11/16	74.3	7.0	17.1	0.92
HVN4-1/2U	1/2	1/2	0.59	1.61	0.93	1.38	1.52	0.94	0.43	0.83	7/8	97.1	7.0	16.8	0.91



Union Straight

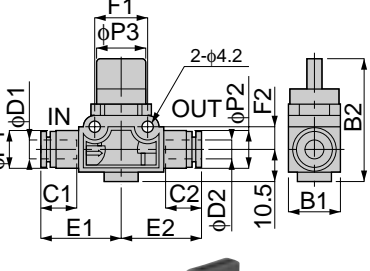

unit:mm

Model	Tube dia. φD1	Tube dia. φD2	B1	B2	φP1	φP2	φP3	C1	C2	E1	E2	F1	F2	Mass (g)	Orifice (φmm)	Eff. a. (mm ²)
HV 4-4-□-□	4	4	17	40.5	10	10	16.5	15	15	26	26	18	8	23.5	5	3.4
HV 6-6-□-□	6	6	17	40.5	12.5	12.5	16.5	17	17	26	26	18	8	24.5	5	7.2
HV 8-6-□-□	8	6	17	40.5	15	12.5	16.5	18	18	28	28	18	8	25.5	5	8.1
HV 8-8-□-□		8														8.7
HV 10-10-□-□	10	10	21	41	17.5	17.5	19.5	20	20	32.5	32.5	24	11	44	7	17.4
HV 12-10-□-□	12	10	21	41	21	17.5	19.5	23.5	20	35.5	32.5	24	11	50	7	17.5
HV 12-12-□-□		12														18.1
HV 1/4-1/4-□-□	1/4	1/4	17	40.5	12.5	12.5	16.5	17	17	26	26	18	8	24.5	5	8.1
HV 5/16-1/4-□-□	5/16	1/4	17	40.5	15	12.5	16.5	18	17	28	26	18	8	25.5	5	8.8
HV 5/16-5/16-□-□		5/16														8.7
HV 3/8-3/8-□-□		3/8														17



Nipple Type

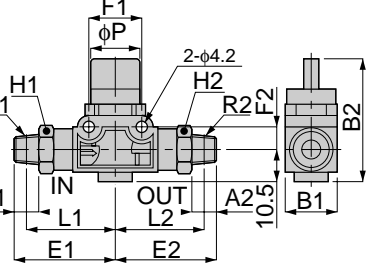

unit:mm

Model	R1	R2	A1	A2	B1	B2	L1	L2	φP	E1	E2	H1	H2	F1	F2	Mass (g)	Orifice (φmm)	Eff. a. (mm ²)
HV 01-01-□-□	R1/8	R1/8	8	8	17	40.5	29.5	29.5	16.5	33.5	33.5	14	14	18	8	42	5	8.8
HV 02-01-□-□	R1/4	R1/8	8	17	40.5	30.5	29.5	16.5	36.5	33.5	14	14	18	8	48.5		9	
HV 02-02-□-□		R1/4	11	21	41	36.5	36.5	19.5	42.5	42.5	17	17	24	11	79.5		15.8	
HV 03-02-□-□	R3/8	R1/4	11	21	41	37	36.5	19.5	43.5	42.5	17	17	24	11	96	7	15.6	
HV 03-03-□-□		R3/8															15.7	



unit:inch

MODEL	NPT1	NPT2	A1	A2	B	L1	L2	E1	E2	F1	F2	H1	H2	W	Weight (g)	Orifice φmm	Eff. A. mm ²	Cv
HVN1-N1U	1/8	1/8	0.31	0.31	1.59	1.16	1.16	1.32	1.32	0.71	0.30	9/16	9/16	0.67	43.0	5.0	8.8	0.47
HVN2-N1U	1/4	1/8	0.43	0.31	1.59	1.16	1.16	1.44	1.32	0.71	0.30	9/16	9/16	0.67	48.9	5.0	9.0	0.48
HVN2-N2U	1/4	1/4	0.43	0.43	1.61	1.42	1.42	1.67	1.67	0.94	0.43	11/16	11/16	0.83	81.1	5.0	15.8	0.85
HVN3-N2U	3/8	1/4	0.47	0.43	1.61	1.42	1.42	1.71	1.67	0.94	0.43	11/16	11/16	0.83	89.5	5.0	15.6	0.84
HVN3-N3U	3/8	3/8	0.47	0.47	1.61	1.46	1.46	1.71	1.71	0.94	0.43	11/16	11/16	0.83	97.7	7.0	15.7	0.85